

reflex

Thinking solutions.

Deaeration systems & Separation technology



Servitec, Ex-separators



From the initial idea
to the solution



Reflex - The Company

Smooth operation in supply engineering thanks to system solutions

Reflex Winkelmann GmbH belongs to the Heating&Water division of the Winkelmann Group with 4,200 employees worldwide. The company is a leading brand manufacturer and solution provider for the smooth operation of water-carrying systems in supply engineering and modern building services. In addition to expansion vessels, we develop, manufacture and distribute innovative components and complete solutions for pressure-maintaining, water make-up, degassing, water treatment and storage as well as heat exchangers.

Extensive Product Range

Reflex represents a large range of products and services, offering innovative systems for heating, cooling and hot-water supply and a multitude of other services.

The Reflex product range comprises:











- Expansion Vessels
- Pressurisation Systems
- Water Make-Up Systems & Water Treatment
- Degassing Systems & Separation Technology
- Hot Water Storage Tanks & Heat Exchangers

For constant reliable heat and water supply.

www.reflex.de

Contents

Deaeration Systems & Separation Technolog

	Deaeration Systems & Separation Technology	4
	Servitec Control unit	6
	Servitec system components	7
	Servitec working principle	9
	Servitec 30 technical data	10
	Servitec 35-120 technical data	11
	Servitec options	12
	Servitec product application	13
	Comparison of different deaeration systems	14
	Exvoid T	17
	Exvoid brass	18
	Exvoid steel	19
	Exvoid steel Hi-Cap	20
	Exdirt brass	21
	Exdirt steel & Exdirt steel with flange	22
	Exdirt steel Hi-Cap & Exdirt steel Hi-Cap with flange	24
	Extwin brass	26
	Extwin steel & Extwin steel with flange	27
	Extwin steel Hi-Cap & Extwin steel Hi-Cap with flange	29
	Reflex EB traditional dirt collector	31
	Reflex LA traditional air separator	31
	Reflex T expansion trap	31
	Accessories : Exferro - Exiso	32
	Pressure loss diagram	32
	Tailor - made Solutions	35

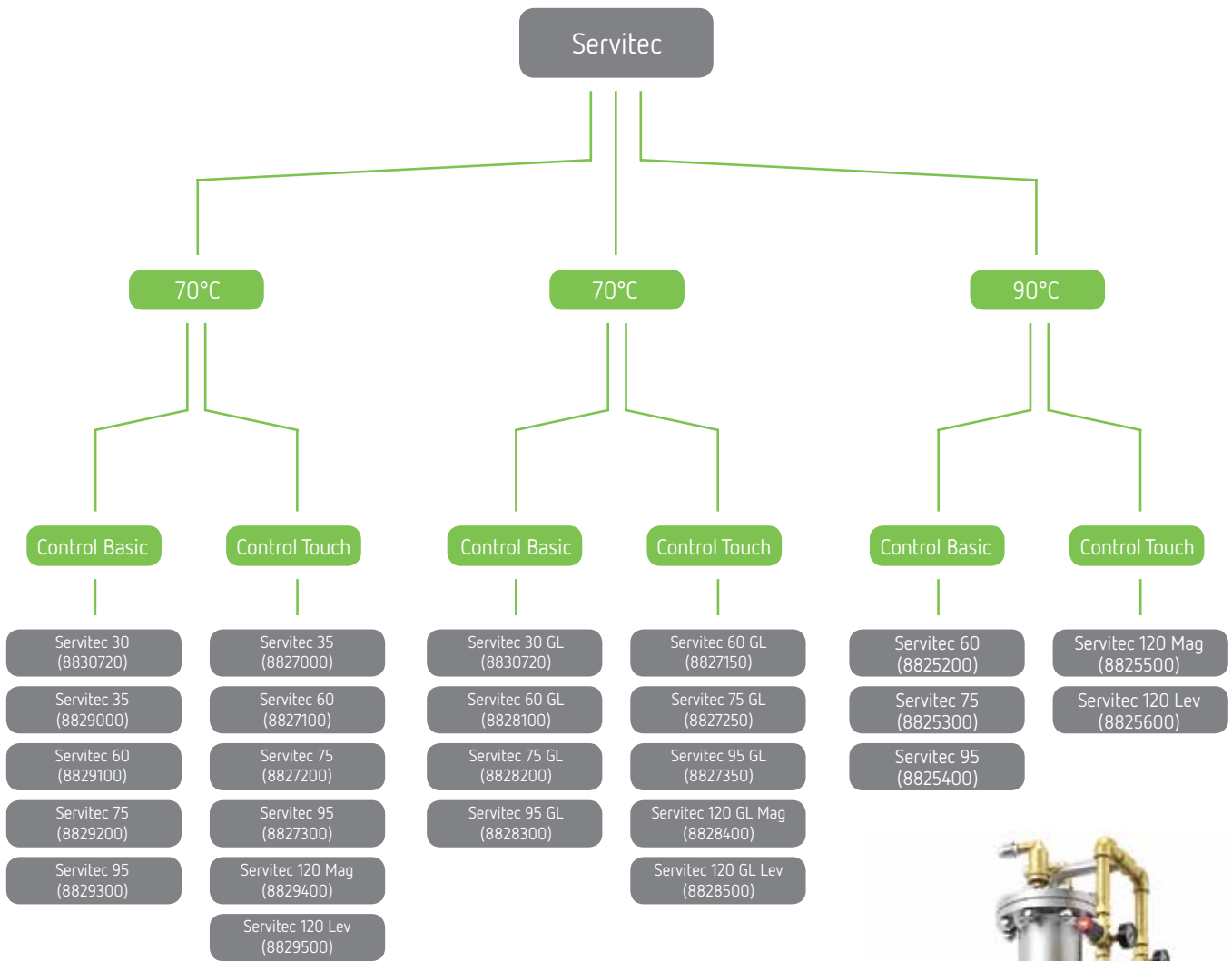

Servitec

Deaeration Systems & Separation Technology



Reflex Control

Control Basic



- 2-line LCD display
- 8 control keys
- 2 status LED Integrated control of system pressure, deaeration and water make-up
- Manual and automatic operation
- Common fault output signal
- Input, for contact water meter
- RS-485 interface

Control Touch



- 4.3" touch screen colour display
- Graphic user interface
- Simply structured plain text menus including operating instructions and help texts
- Integrated control of system pressure, deaeration and water make-up
- Manual and automatic operation
- Permanent display of the most important operating parameters in the system diagram
- Intelligent Plug & Play operational management
- Evaluation and storage of the most important operational data
- Extensive interfaces:
 - Input, for contact water meter
 - 2 x dry contact outputs for error messages
 - 2 x analogue outputs for pressure and vessel content
 - 2 x RS-485 interfaces
 - Plugs for Bluetooth module and HMS networks, as well as SD card

Control Remote NEW!



- Remote control via secure server
- System monitoring via PC or mobile device at any time and everywhere
- (Professional) remote servicing by Reflex Customer Service
- Reflex Remote Portal with intuitive user interface
- Simple management of multiple installations
- Visualisation of all parameters
- Diagrams for run-time monitoring
- Alarm messages via e-mail or messaging
- User-provided Internet or GSM connection
- Factory-installed or retrofitting, independent of Touch or Basic



Servitec

Patented Technology for Optimum Degassing

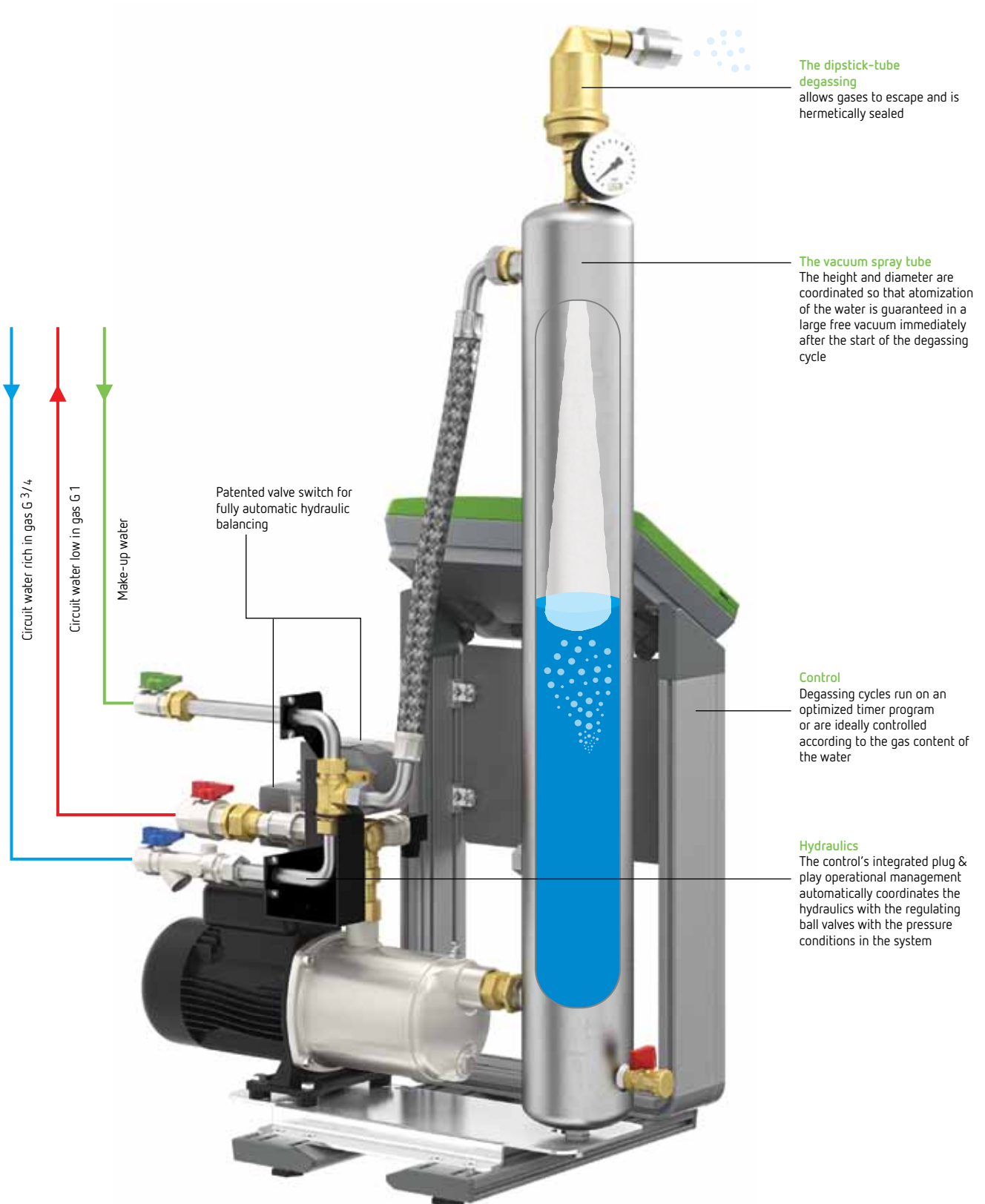

The dipstick-tube degassing
allows gases to escape and is hermetically sealed

The vacuum spray tube
The height and diameter are coordinated so that atomization of the water is guaranteed in a large free vacuum immediately after the start of the degassing cycle

Control
Degassing cycles run on an optimized timer program or are ideally controlled according to the gas content of the water

Hydraulics
The control's integrated plug & play operational management automatically coordinates the hydraulics with the regulating ball valves with the pressure conditions in the system

Servitec in Magcontrol and Levelcontrol Mode

Reflex Servitec in magcontrol mode combined with expansion vessel system

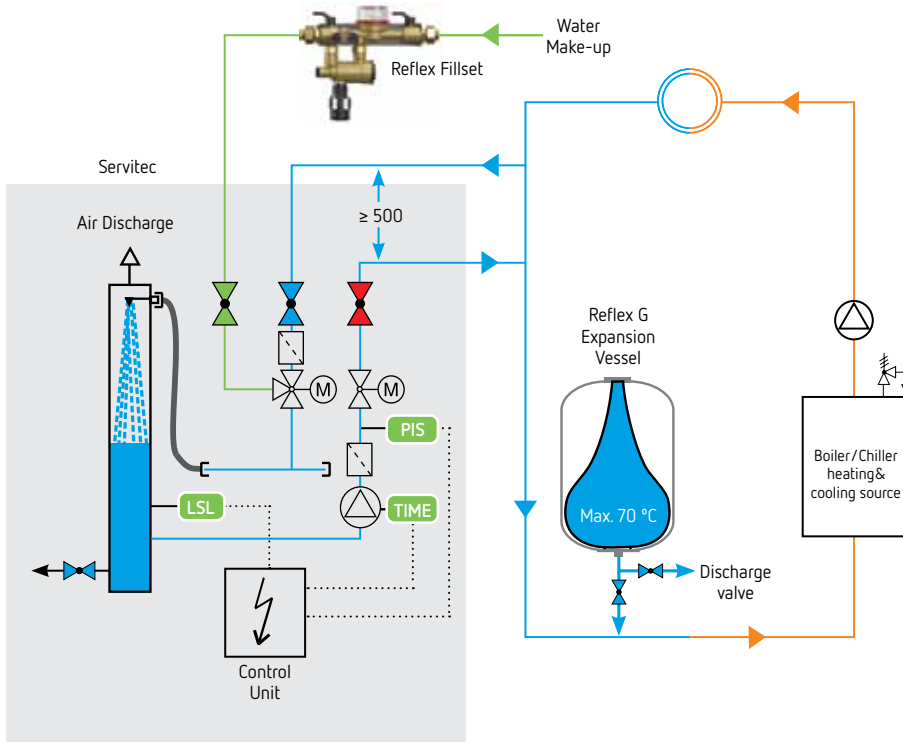

PIS

Filling - Make-Up,
Pressure-Dependent-
Magcontrol

The pressure is shown in the display Excess and insufficient pressure levels are signaled Automatic, controlled make-up in the event that the system fails to reach the filling pressure of 0.2 bar Servitec degassing of the make-up and filling water

TIME

Degassing

Vacuum degassing of a part flow of the circuit water takes place according to an optimized schedule using a selectable degassing mode.

- Continuous degassing (after start-up)
- Interval degassing (automatically activated after continuous degassing)

Reflex Servitec in levelcontrol mode for systems with compressor controlled pressure maintaining station

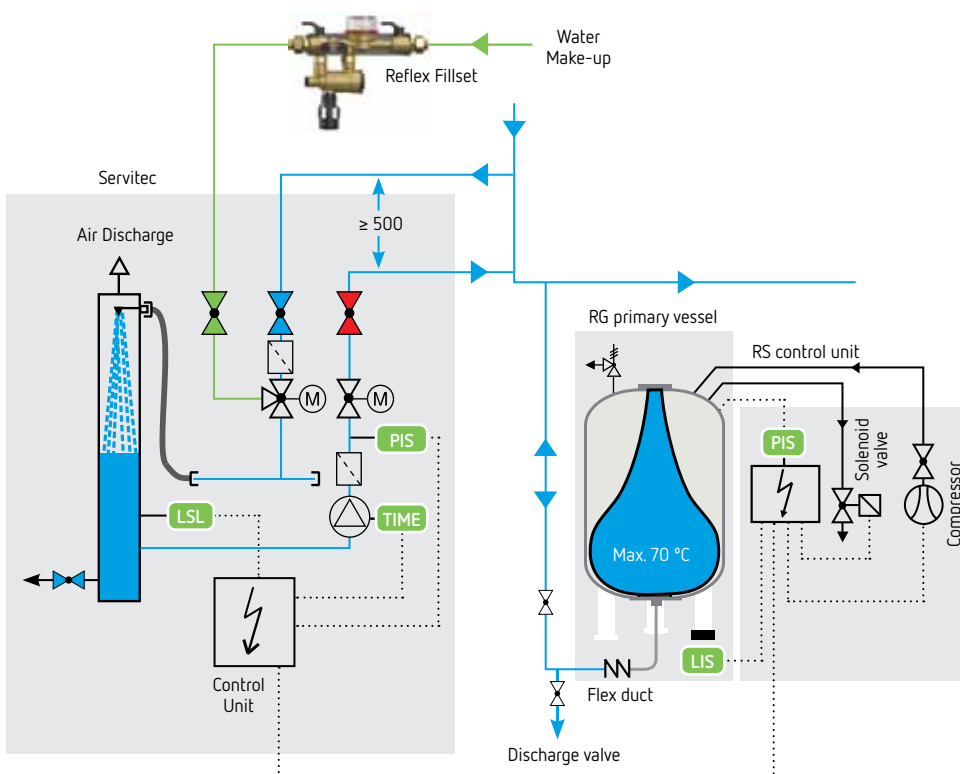

LIS

Water Make-up,
Level-Dependent
Levelcontrol

Automatic, controlled water make-up if the minimum water level is not reached in the expansion vessel of the compressor controlled pressure - maintaining station Servitec degassing of the make-up water

Servitec Working Principle

Vacuum generation

The pumps cuts in, the water level drops and a vacuum is generated in the vacuum spray tube.

The circuit water (optionally make-up water) is atomised in the generated vacuum releasing the dissolved gases due to the vacuum and the large contact surface.

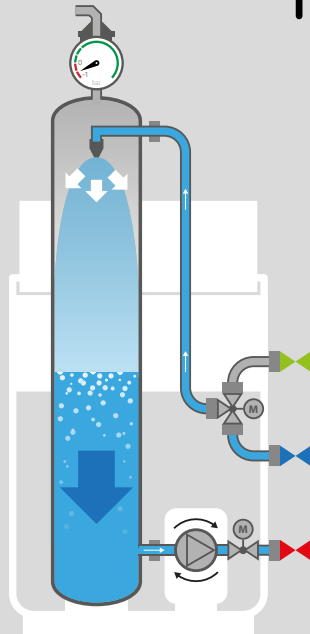

Degassing start

The pump shuts down. Water is sprayed until the vacuum spray tube is completely filled.

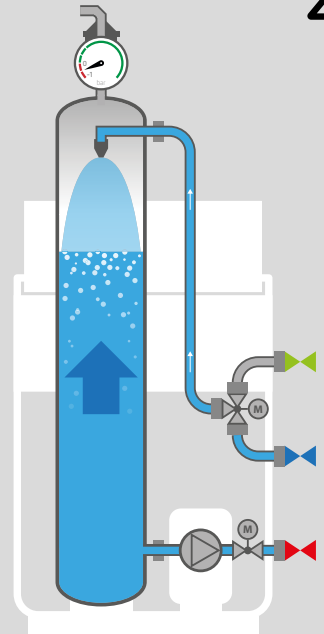

Degassing

All released gases are reliably precipitated via the automatic fan.

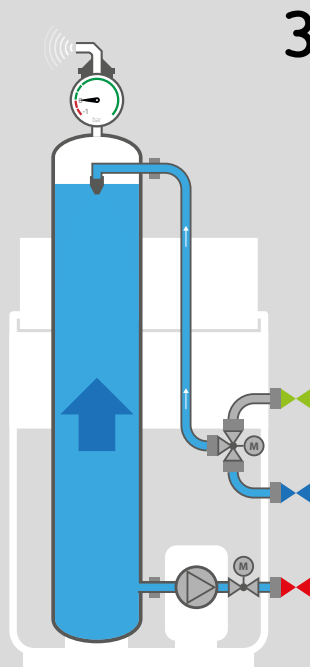

Idling time

System pressure has built up in the spray tube. The system water within the tube is nearly gas-free and will be returned to the network in the following cycle.

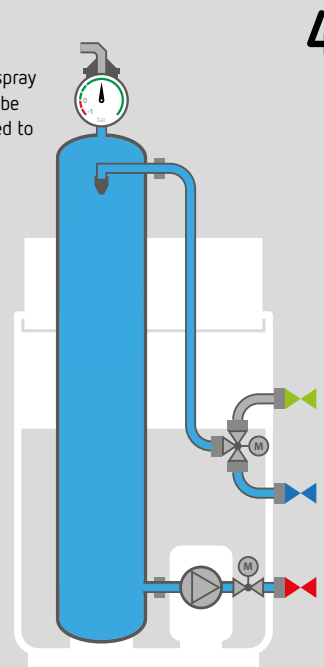

Video clips demonstrating the function of this and other products are available under www.reflex.de/services/fachwissen-und-beitraege/videothek/

Servitec 30

- Deaeration with intergrated water make-up systems used in conjunction with diaphragm expansion vessels or pressurisation systems
- Ideally suited for offices and commercial buildings
- Flexible adjustment of the Servitec Magcontrol or Levelcontrol operating modes
- Central deaeration of the water in the system and make-up water
- Max. operating pressure: 8 bar
- Max. operating temperature: 70°C
- Microprocessor controller with plain text display for pressure
- Floating contact for common message
- Simple commissioning with auto setup
- Patented, fully automatic overflow regulation
- Safe control (water make-up using the actuator valve)
- Water make-up is possible from a storage tank (on site)

The Servitec 30 Mobile is based on the design of the standard unit Servitec 30. The unit is extended by a transport aid and is used for the mobile application of vacuum spray tube degassing of system and refill water for closed heating or chilled water circuits.



Servitec 30
Wall mounted

Mobile Servitec :
optional up on demand
Servitec 30 Mobile with Schuko plug
Article No : 8828650
Servitec 30 Mobile with plug Typ J (CH)
Article No : 8828600

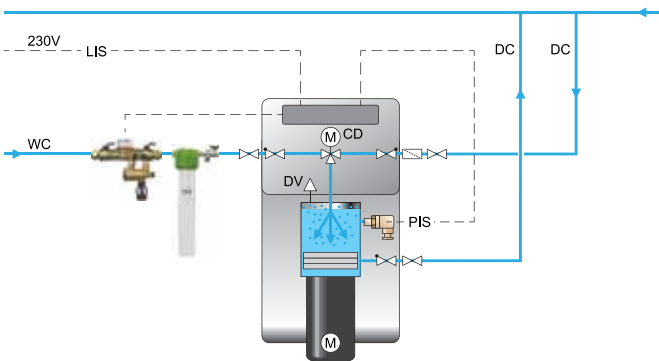

	Type	Control Basic Article No	Material Group	System Volume Vs (m³), 70°C	Working Pressure (bar) 70°C	Make-up Rate (m³/h)	H x W x D mm	Power W	Voltage V	Weight kg
70°C	30	8830720	71	≤ 12*	0.5 - 3.0	≤ 0.025	660 x 545 x 290	470 W / 10 A	230 V / 50 Hz	13.0
	30/gl	8828900	71	≤ 4	0.5 - 3.0	≤ 0.025	660 x 545 x 290	470 W / 10 A	230 V / 50 Hz	13.0

* Max. facility volumes for system degassing / max. water make-up quantities must be taken into account for the specific facility.

1. Controller
2. Venting grille
3. Dirt trap
4. Airvent
5. 3 way motor ball valve
6. Pressure transducer
7. Vacuum degassing pump
8. Removable front shell

- WC: Make-up connection
DC : Degassing connection
- DC 1 Gas-rich water inlet
 - DC 2 Degassed water outlet

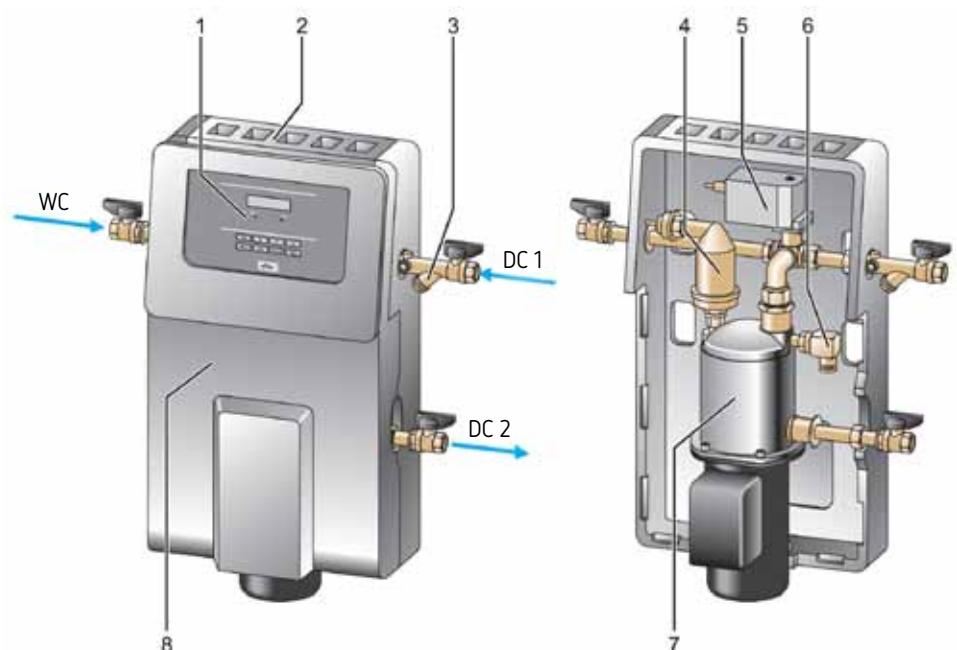

Servitec 35 - 120

- Vacuum spray-tube deaeration with intergrated water make-up systems used in conjunction with diaphragm expansion vessels or pressurisation systems
- Ideally suited for high-rise buildings and district heating / cooling systems
- Flexible adjustment of the Servitec Magcontrol or Levelcontrol operating modes
- Central deaeration of the water in the system and make-up water
- Max. operating pressure:
 - 8 bar - type 25, 35, 60
 - 10 bar - type 75, 95, 120
- Max. flow temperature: 120°C
- Microprocessor controller with plain text display for pressure
- Floating contact for common message
- Simple commissioning with auto setup
- Patented, fully automatic overflow regulation
- Safe control (water make-up using the actuator valve)
- Water make-up is possible from a storage tank (on site)
- Control Touch from Servitec 120



Servitec 35-95
Floor standing

Type	Article No	Material Group	System Volume Vs (m ³)	Working Pressure (bar)	Make-up Rate (m ³ /h)	H x W x D mm	Power kW	Voltage V	Weight kg	
Permissible maximum operating temperature: 70°C with Control Basic										
70°C	35	8829000	71	≤ 220	0.5 - 2.5	≤ 0.35	1.030 x 620 x 440	0.7 kW/ 10 A	230 V / 50 Hz	42.0
	60	8829100	71	≤ 220	0.5 - 4.5	≤ 0.55	1.215 x 685 x 440	1.1 kW/ 10 A	230 V / 50 Hz	40.0
	75	8829200	71	≤ 220	0.5 - 5.4	≤ 0.55	1.215 x 600 x 525	1.1 kW/ 10 A	230 V / 50 Hz	39.0
	95	8829300	71	≤ 220	0.5 - 7.2	≤ 0.55	1.215 x 600 x 525	1.1 kW/ 10 A	230 V / 50 Hz	40.0

Permissible maximum operating temperature: 70°C with Control Touch										
70°C	35	8827000	71	≤ 220	0.5 - 2.5	≤ 0.35	1.030 x 620 x 440	0.7 kW/ 10 A	230 V / 50 Hz	30.0
	60	8827100	71	≤ 220	0.5 - 4.5	≤ 0.55	1.215 x 685 x 440	1.1 kW/ 10 A	230 V / 50 Hz	36.0
	75	8827200	71	≤ 220	0.5 - 5.4	≤ 0.55	1.215 x 600 x 525	1.1 kW/ 10 A	230 V / 50 Hz	41.0
	95	8827300	71	≤ 220	0.5 - 7.2	≤ 0.55	1.215 x 600 x 525	1.1 kW/ 10 A	230 V / 50 Hz	42.0
	Magcontrol 120	8827400	71	≤ 220	1.3 - 9.0	≤ 0.55	1.215 x 600 x 525	1.5 kW/ 10 A	400 V / 50 Hz	43.0
Levelcontrol 120	8827500	71	≤ 220	1.3 - 9.0	≤ 0.55	1.215 x 600 x 525	1.5 kW/ 10 A	400 V / 50 Hz	43.0	

Permissible maximum operating temperature: 90°C with Control Touch										
90°C	60	8825200	71	≤ 220	1.3 - 4.0	≤ 0.55	1.215 x 685 x 440	1.1 kW/ 10 A	230 V / 50 Hz	40.0
	75	8825300	71	≤ 220	1.3 - 4.9	≤ 0.55	1.215 x 600 x 525	1.1 kW/ 10 A	230 V / 50 Hz	39.0
	95	8825400	71	≤ 220	1.3 - 6.7	≤ 0.55	1.215 x 600 x 525	1.1 kW/ 10 A	230 V / 50 Hz	40.0
	Magcontrol 120	8825500	71	≤ 220	1.3 - 9.0	≤ 0.55	1.215 x 600 x 525	1.5 kW/ 10 A	400 V / 50 Hz	43.0
	Levelcontrol 120	8825600	71	≤ 220	1.3 - 9.0	≤ 0.55	1.215 x 600 x 525	1.5 kW/ 10 A	400 V / 50 Hz	43.0

Permissible maximum operating temperature: 70°C, suitable for glycol with Control Basic										
70°C GL	60 GL	8828100	71	≤ 50	0.5 - 4.5	≤ 0.55	1.215 x 685 x 440	1.1 kW/ 10 A	230 V / 50 Hz	40.0
	75 GL	8828200	71	≤ 50	1.3 - 4.9	≤ 0.55	1.215 x 600 x 525	1.1 kW/ 10 A	230 V / 50 Hz	39.0
	95 GL	8828300	71	≤ 50	1.3 - 6.7	≤ 0.55	1.215 x 600 x 525	1.1 kW/ 10 A	230 V / 50 Hz	49.0

Permissible maximum operating temperature: 70°C, suitable for glycol with Control Touch										
70°C GL	60 GL	8827150	71	≤ 50	0.5 - 4.5	≤ 0.55	1.215 x 685 x 440	1.1 kW/ 10 A	230 V / 50 Hz	36.0
	75 GL	8827250	71	≤ 50	1.3 - 4.9	≤ 0.55	1.215 x 600 x 525	1.1 kW/ 10 A	230 V / 50 Hz	41.0
	95 GL	8827350	71	≤ 50	1.3 - 6.7	≤ 0.55	1.215 x 600 x 525	1.1 kW/ 10 A	230 V / 50 Hz	42.0
	Magcontrol 120 GL	8828400	71	≤ 50	1.3 - 8.3	≤ 0.55	1.215 x 600 x 525	1.5 kW/ 10 A	400 V / 50 Hz	43.0
	Levelcontrol 120 GL	8828500	71	≤ 50	1.3 - 8.3	≤ 0.55	1.215 x 600 x 525	1.5 kW/ 10 A	400 V / 50 Hz	43.0

Special designs upon request: System volume > 220 m³ and operating pressure > 9.0 bar (see page 54, Variomat)

Magcontrol: For systems with diaphragm-type expansion vessels.

Levelcontrol: For systems with pressurisation systems

BMS Modules

Type	Article No	Material Group	Weight kg
LonWorks Digital	8860000	86	1.5
LonWorks	8860100	86	1.9
Profi bus-DP	8860200	86	1.9
Ethernet	8860300	86	1.9
BACnet-IP for Control Touch	8860500	86	0.4
BACnet MS/TP for Control Touch	8860600	86	0.4
Modbus RTU for Control Touch	9125592	86	0.4
Profibus RTU for Control Touch	9118042	86	0.4
I/O Modules	8860400	71	1.0



Control Remote

Remote monitoring, diagnostics and at last remote-control maintenance are becoming increasingly important for the supervision of supply grid systems. For the responsible on-site operator, it is more and more difficult to find qualified support staff. Long distances to sites frequently prevent quick and continuous control.

Type	Article No	Material Group	Length mm	Width mm	Height	Weight kg
Control Remote	8910800	86	83	60	34	0.3

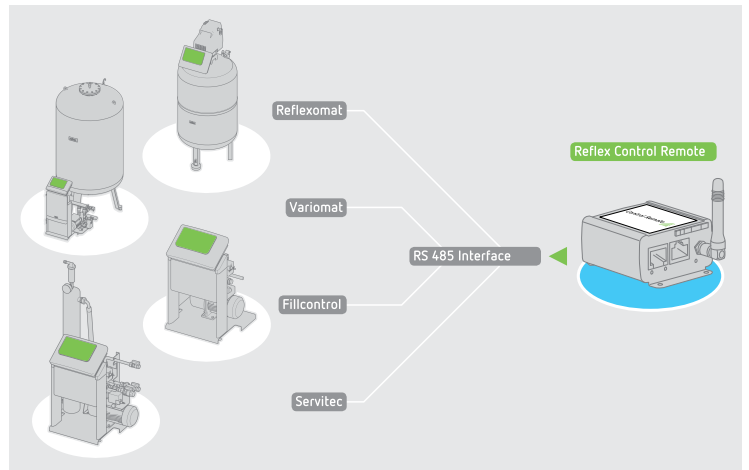

Optional: Servitec for Large Scale Systems

- Special systems are constructed to match your particular specifications even for systems above 10.000 m3 with working pressure above 9 bar.
- Also, for systems with permissible operating temperature up to 90°C
- Take advantage of our combined expertise and experience:
Consult your Reflex Local representative or visit www.reflex.de/pro for further information.

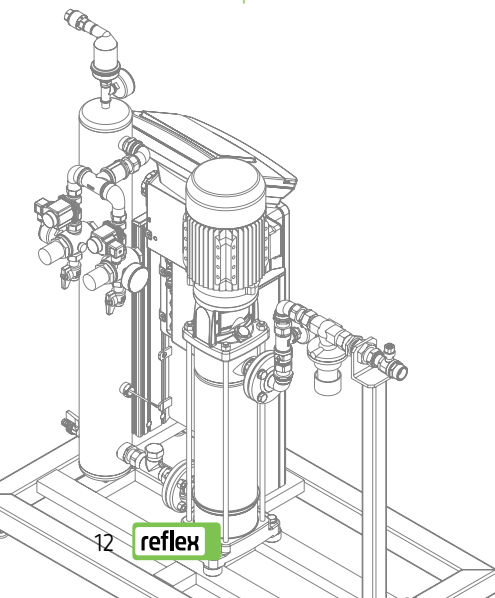

Tailor made Servitec unit (front view)

Tailor made Servitec unit (rear view)

Servitec 30 With Reflex G Vessel and Water Make-up

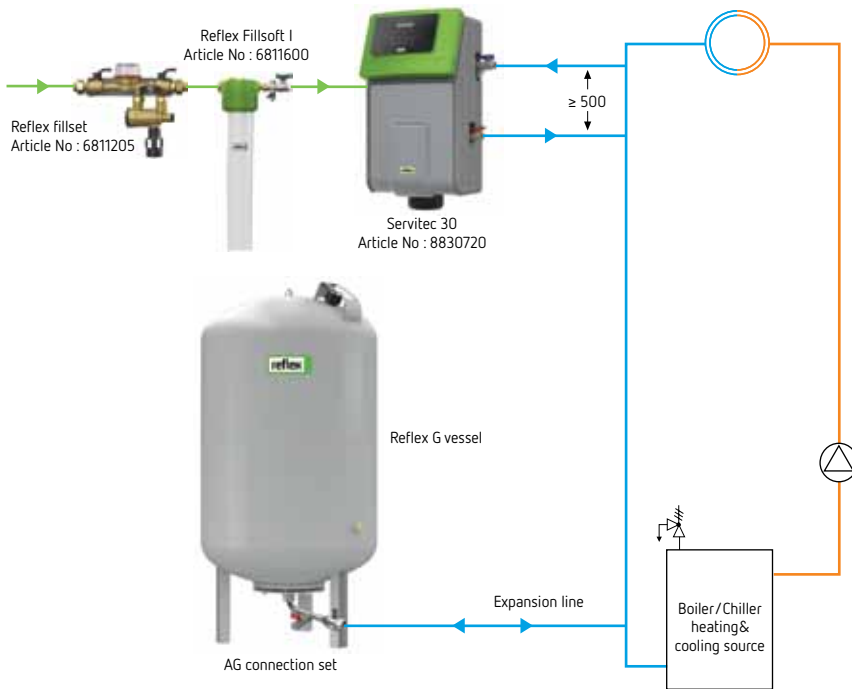

Static vessel in combination with Servitec 30 and Fillset RPZ valve. If the water level in the vessel drops to a critical level, an appropriate amount of water will be filled into the unit from the water mains via the Servitec device.

By connecting the Servitec device in Magcontrol mode make-up water is de-aerated before going into the system. The Fillset RPZ valve protects against backflow, providing protection against the contamination of mains cold water supply according to EN1717.

This combination can also be used for applications where the water supply comes from an adjacent container, as the Servitec device is self priming.

In cooling application systems : Servitec deaeration unit needs to be placed into the flow before the system circulation pump.

Servitec 30 With Reflex G Vessel and Water Make-up

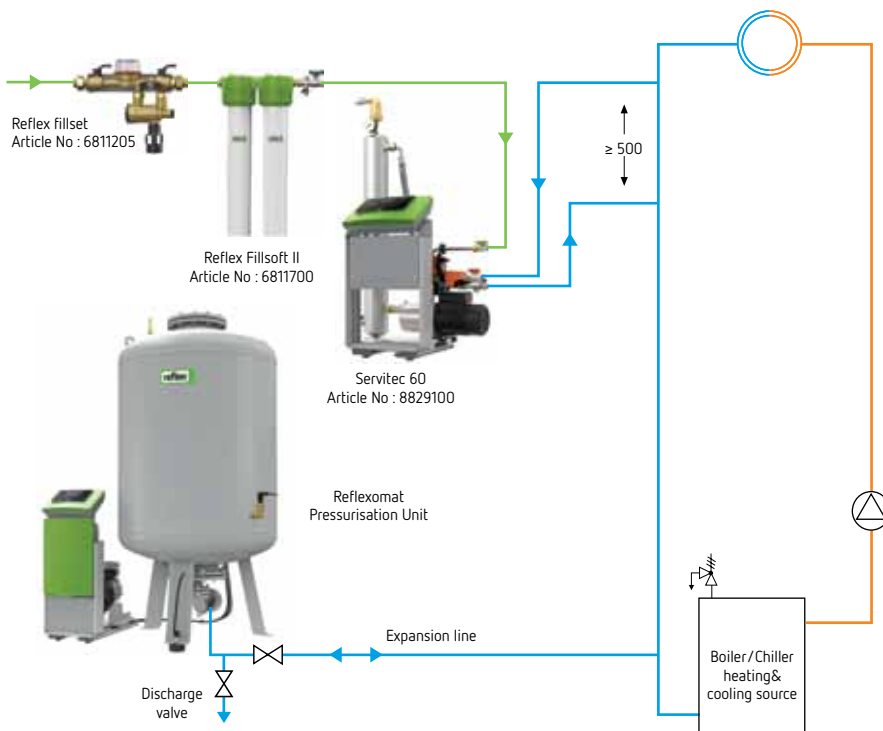

Reflexomat unit in combination with Servitec, Fillsoft II water softening device and Fillset RPZ valve. If the water level in the vessel drops to a critical level, an appropriate amount of water will be filled through the Servitec from the water mains. By the Fillsoft device the system water can be totally softened or adjusted to the required level by Servitec.

The Fillset RPZ valve protects against backflow, providing protection against the contamination of mains cold water supply according to EN1717. By connecting the contact water meter to the Variomat control unit the Fillmeter function is available.

In cooling application systems : Servitec deaeration unit needs to be placed into the flow before the system circulation pump.

Comparison of Different Deaeration Systems

In order to illustrate the effectiveness of different deaeration systems, we would like to show the physically and technically achievable, minimum nitrogen content in the network water in dependence on the pressure conditions at the place of installation. Nitrogen serves as "measurement gas" because it is an inert gas and is, thus, not consumed in secondary reactions. This leads to an unbiased measurement result.

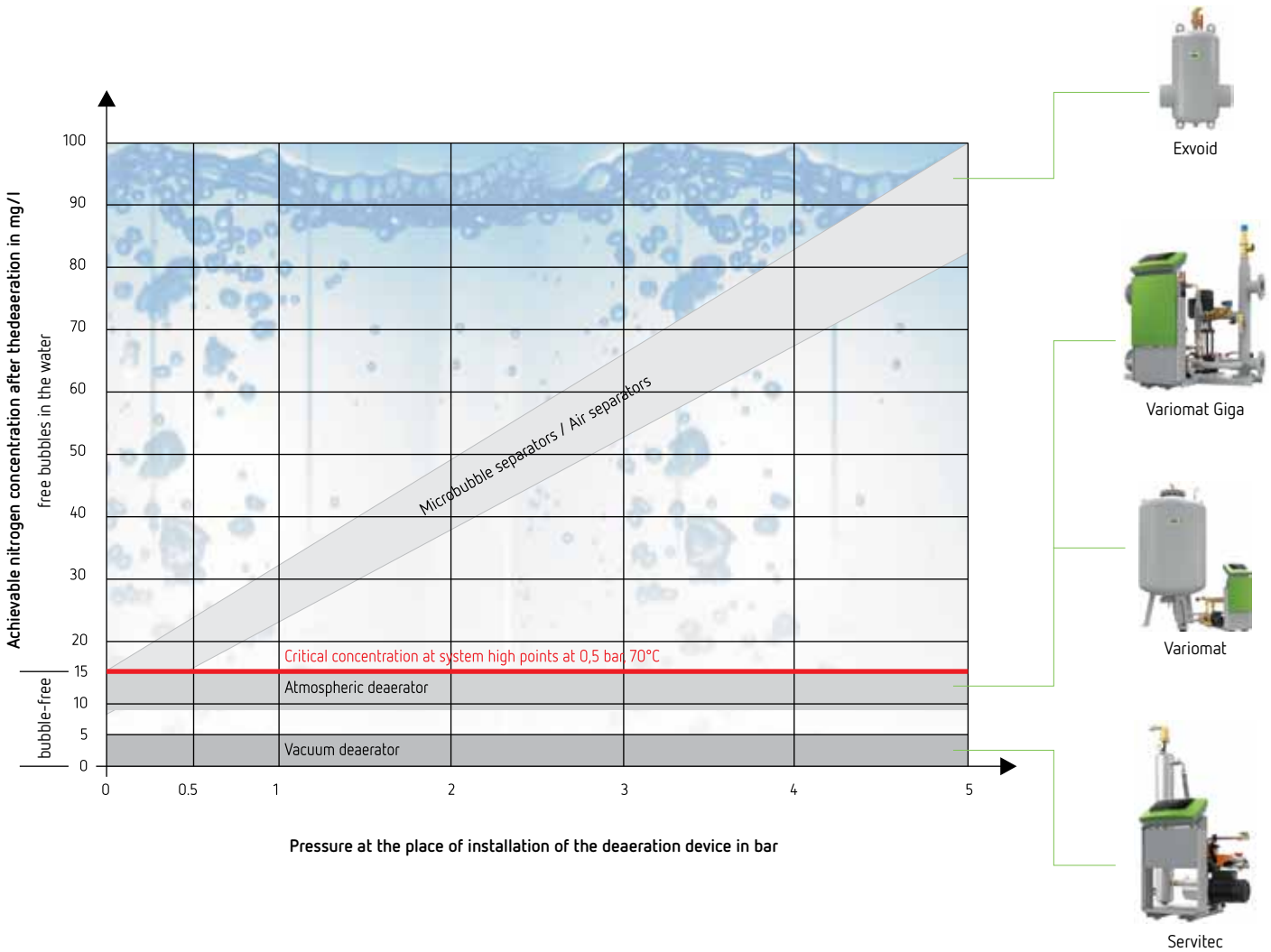

Mechanical air separators

Can only work effectively if they are installed at high points.

Atmospheric deaerators

Can prevent the formation of free gas bubbles in the circulation water. They are the best solution as a central bleeding device, but not for the purposeful oxygen separation. Erosion due to two-phase flow can be avoided to the greatest possible extent.

Vacuum deaerators

Can reduce the overall gas content almost to zero. They combat corrosion (reactive gases) as well as erosion (inert gases). High degrees of separation are achieved using dynamic vacuum deaerators.

Separation Technology

Deaeration Systems & Separation Technology



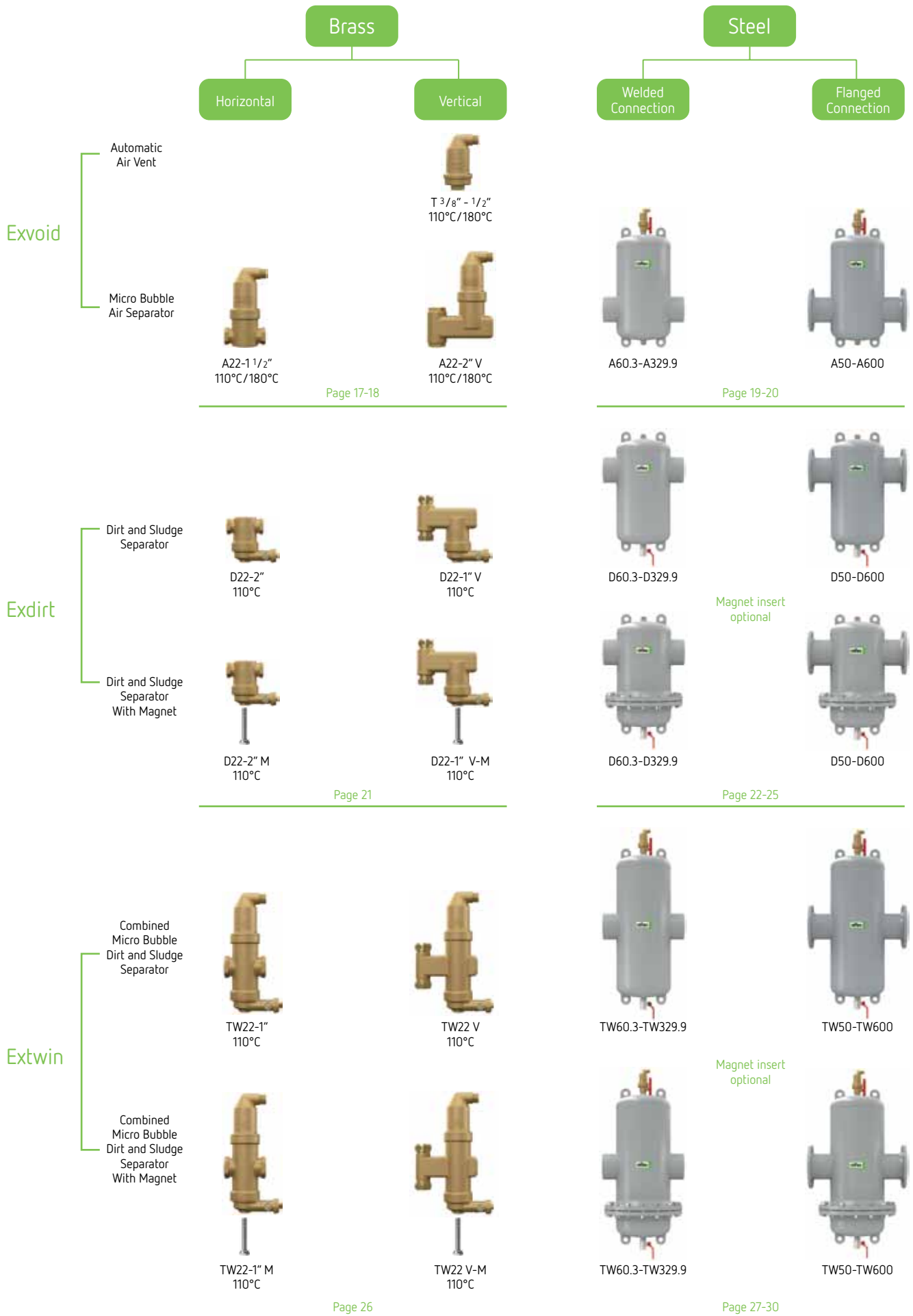

Exvoid T



Exvoid T Function Diagram

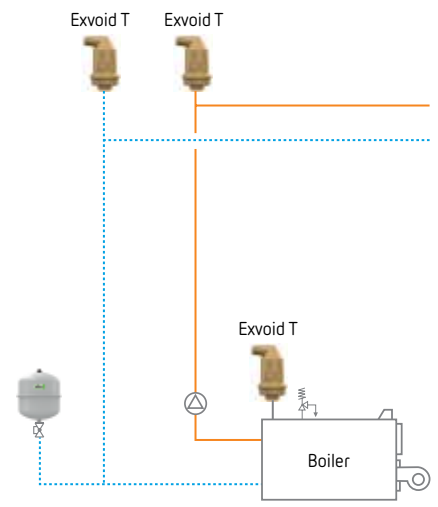

Exvoid T system air venting sketch

Overview

- Brass casing
- Multiple testing procedure on the deaeration valve
- Vertical installation
- Rp 1/2 system connection and a G 1/2 connection thread on the deaeration valve
- Application limits 110 / 180°C and 10 bar

Exvoid T Automatic Air Vent

Fields of application

The automatic air vent in the reflex Exvoid T series is an ongoing and effective way of removing air and other gases from heating, solar, and cooling systems, including under constant operating conditions, in filling processes after having emptied the system, and in new installations. The vents are applied at high points within the system or at specially identified collection points

Mode of operation

In order to ensure ongoing safe and automatic operation, Reflex Exvoid T automatic air vents follow a sound engineering design formula: Gases collect in a generously sized chamber. This causes the water level in the chamber to drop and a float to fall, which opens the deaeration valve once it reaches a certain depth. The combination of a multiple-tested valve and a generously sized air chamber ensures flawless operation, even in extreme pressure fluctuations

T, brass

- 110°C 10 bar

Type	Article No	Weight kg	Material Group	Connection	Ø (mm)	H (mm)
Exvoid T 1/2	9250000	0.7	82	G 1/2 female	63	120
Exvoid T 3/8	9250038	0.7	82	G 3/8 male	63	132



T Solar, brass

- 180°C 10 bar

Type	Article No	Weight kg	Material Group	Connection	Ø (mm)	H (mm)
Exvoid T 1/2 S	9250600	0.7	82	G 1/2 female	63	120



Benefits in brief

- Reliable, automatic deaeration
- Reduces flow noise, circulation problems, drop in performance and helps to avoid corrosion damage
- Optimum function reliability, even in tough conditions
- Reduces maintenance requirements
- Suitable for a variety of temperatures and applications

Exvoid

The core element is a tube mesh construction that has proven itself over the decades, with an extremely low rate of pressure loss in the flow direction and a high rate of pressure loss in the transverse direction. This drastically reduces the amount of turbulence and guides the gas bubbles to a part-stabilized area

Volumetric flow:
1.25 - 8 m³/h

Exiso thermal insulation:
A22 - 2"

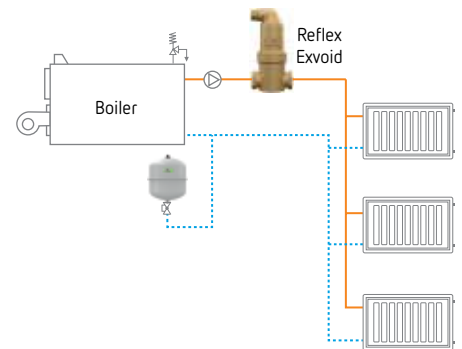

Exvoid "brass" system deaeration sketch

Exvoid (Brass) Micro Bubble Air Separator

Brass, 110°C 10 bar
• Horizontal

Type	Article No	Weight kg	Material Group	Connection	\dot{V} max m ³ /h	L mm	Ø mm	H mm
A 22	9251000	1.1	82	22 mm ¹⁾	1.25	106	63	165
A 3/4	9251010	1.0	82	G 3/4	1.25	85	63	165
A 1	9251020	1.1	82	G 1	2.00	88	63	180
A1 1/4	9251030	1.3	82	G 1 1/4	3.70	88	63	202
A1 1/2	9251040	1.5	82	G 1 1/2	5.00	88	63	236
A 2	9251050	3.2	82	G 2	8.00	132	100	277

¹⁾ Clamp ring

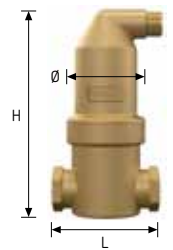

Brass, 110°C 10 bar
• Vertical

Type	Article No	Weight kg	Material Group	Connection	\dot{V} max m ³ /h	L mm	Ø mm	H mm
A 22	9251000	1.1	82	22 mm ¹⁾	1.25	106	63	165
A 3/4	9251010	1.0	82	G 3/4	1.25	85	63	165
A 1	9251020	1.1	82	G 1	2.00	88	63	180

¹⁾ Clamp ring

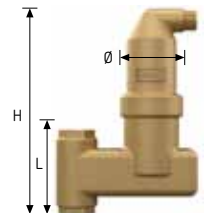

Brass, 180°C 10 bar
• For solar systems

Type	Article No	Weight kg	Material Group	Connection	\dot{V} max m ³ /h	L mm	Ø mm	H mm
A 22 S	9251600	1.2	82	22 mm ¹⁾	1.25	106	63	165
A 3/4 S	9251610	1.1	82	G 3/4	1.25	85	63	165
A 1 S	9251620	1.2	82	G 1	2.00	88	63	185
A 1 1/4 S	9251630	1.4	82	G 1 1/4	3.70	88	63	202
A 1 1/2 S	9251640	1.6	82	G 1 1/2	5.00	88	63	236

¹⁾ Clamp ring

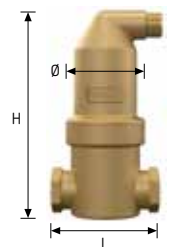

Brass, 180°C 10 bar
• For solar systems

Type	Article No	Weight kg	Material Group	Connection	\dot{V} max m ³ /h	L mm	Ø mm	H mm
A 22 SV	9251700	1.8	82	22 mm ¹⁾	1.25	104	63	220
A 3/4 SV	9251710	1.7	82	G 3/4	1.25	84	63	206
A 1 SV	9251720	1.7	82	G 1	2.00	84	63	206

¹⁾ Clamp ring

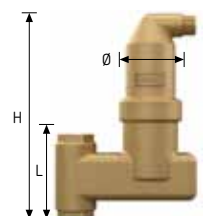

Exvoid

Because micro-bubbles are carried along by the flow, special measures are required in order to remove them from the system efficiently. The casings of Reflex Exvoid micro-bubble separators have a larger cross-section than the connection dimensions, which reduces the flow speed in the separator. At the same time, the volume flow is guided by a special wire mesh. The ensuing turbulence causes gas bubbles to move in an undetermined direction. Depending on the volume flow, density, and volume of the particles, parts of these gas bubbles are supported in their natural breakaway motion and removed from the system via the deaeration top section

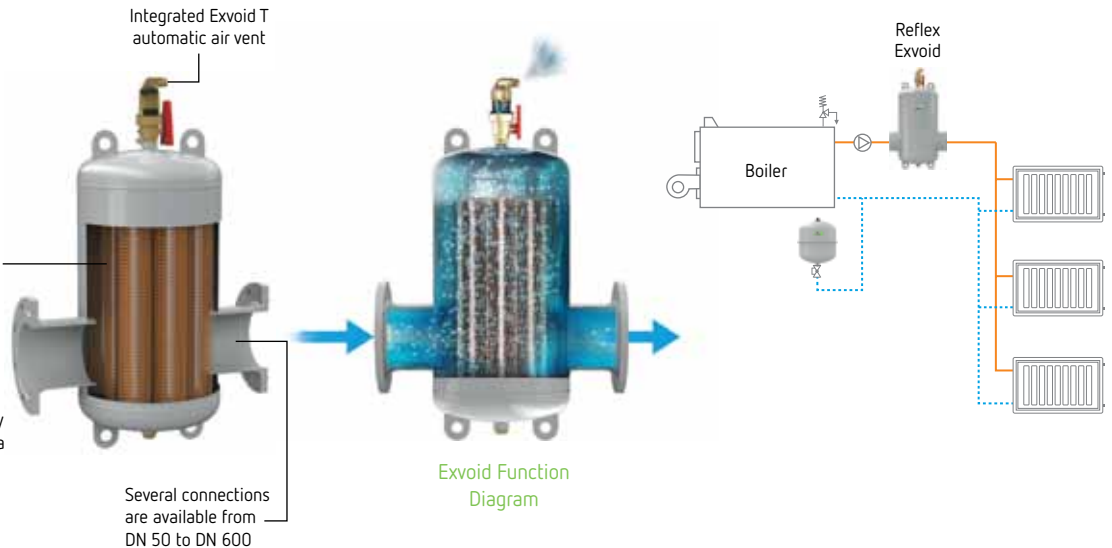

Overview

- Connection: DN 50 - DN 600
- Volumetric flow: 12.5 - 1530 m³/h
- Exiso thermal insulation: DN 50 - DN 150

Exvoid (Steel) Micro Bubble Air Separator

Steel, 110°C 10 bar

- Welded connection

Type	Article No	Weight kg	Material Group	Connection	\dot{V} max m ³ /h	L mm	Ø D mm	H mm	HB mm
A 60.3	8251100	5	83	60.3	12.5	260	132	625 ¹⁾	153
A 76.1	8251110	5	83	76.1	20.0	260	132	625 ¹⁾	163
A 88.9	8251120	11	83	88.9	27.0	370	206	740 ¹⁾	159
A 114.3	8251130	11	83	114.3	47.0	370	206	740 ¹⁾	169
A 139.7	8251140	24	83	139.7	72.0	525	354	915 ¹⁾	214
A 168.3	8251150	26	83	168.3	108.0	525	354	915 ¹⁾	229
A 219.1	8251160	70	83	219.1	180.0	650	409	1125	284
A 273.0	8251170	108	83	273.0	288.0	750	480	1402	351
A 323.9	8251180	150	83	323.9	405.0	850	634	1612	406

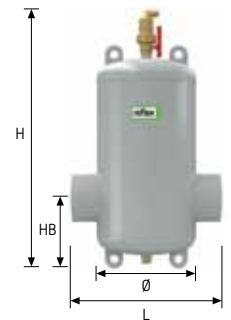

¹⁾ Thermal insulation available

Steel, 110°C 10 bar

- Flange connection

Type	Article No	Weight kg	Material Group	Connection	\dot{V} max m ³ /h	L mm	Ø D mm	H mm	HB mm
A 50	8251300	11	83	DN 50/PN 16	12.5	350	132	625 ¹⁾	153
A 65	8251310	12	83	DN 65/PN 16	20.0	350	132	625 ¹⁾	163
A 80	8251320	18	83	DN 80/PN 16	27.0	470	206	740 ¹⁾	159
A 100	8251330	21	83	DN 100/PN 16	47.0	475	206	740 ¹⁾	169
A 125	8251340	60	83	DN 125/PN 16	72.0	635	354	915 ¹⁾	214
A 150	8251350	64	83	DN 150/PN 16	108.0	635	354	915 ¹⁾	229
A 200	8251360	90	83	DN 200/PN 16	180.0	775	409	1125	284
A 250	8251370	146	83	DN 250/PN 16	288.0	890	480	1402	351
A 300	8251380	194	83	DN 300/PN 16	405.0	1005	634	1612	406
A 350	8251910	Upon request	83	DN 350/PN 16	500.0	1128	634	1950	501
A 400	8251920	Upon request	83	DN 400/PN 16	650.0	1226	750	2150	580
A 450	8251940	Upon request	83	DN 450/PN 16	850.0	1330	750	2360	609
A 500	8251950	Upon request	83	DN 500/PN 16	1060.0	1430	1000	2580	671
A 600	8251960	Upon request	83	DN 600/PN 16	1530.0	1630	1200	3020	832

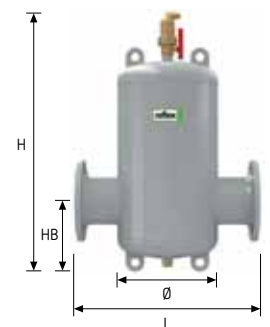

¹⁾ Thermal insulation available

Benefits in brief

- Removes free circulating air and gas bubbles
- Robust heavy gauge steel construction
- Functions in fully automated, continuous operation
- Produces just a minimal, constant drop in pressure
- Enables much faster hydraulic balancing after filling processes
- Prevents development of noise, wear through corrosion, and loss in performance through the formation of larger air bubbles
- Full range in terms of operating pressures, temperatures, and materials

Exvoid HC

Because micro-bubbles are carried along by the flow, special measures are required in order to remove them from the system efficiently. The casings of Reflex Exvoid HC micro-bubble separators have a larger cross-section than the connection dimensions, which reduces the flow speed in the separator. At the same time, the volume flow is guided by a special wire mesh. The ensuing turbulence causes gas bubbles to move in an undetermined direction. Depending on the volume flow, density, and volume of the particles, parts of these gas bubbles are supported in their natural breakaway motion and removed from the system via the deaeration top section

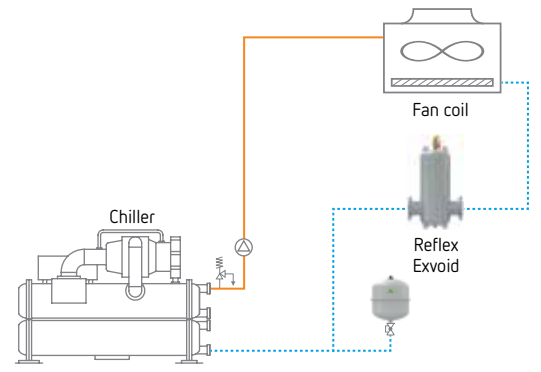
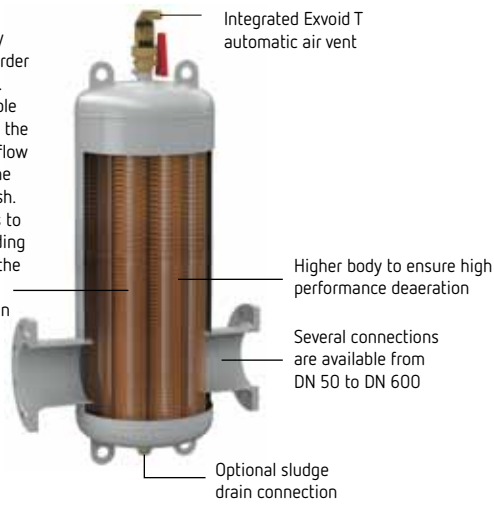

Exvoid "steel" HiCap system deaeration sketch

Overview

- Connection: DN 50 - DN 600
- Volumetric flow: 25 - 3000 m³/h

Exvoid HiCap (Steel) Micro Bubble Air Separator

Steel, 110°C 10 bar
 • Welded connection

Type	Article No	Weight kg	Material Group	Connection	\dot{V} max m³/h	L mm	Ø D mm	H mm	HB mm
A 60.3 HC	9251105	5	83	60.3	25.0	260	132	810	153
A 76.1 HC	9251115	5	83	76.1	40.0	260	132	810	163
A 88.9 HC	9251125	11	83	88.9	54.0	370	206	965	159
A 114.3 HC	9251135	11	83	114.3	94.0	370	206	965	169
A 139.7 HC	9251145	24	83	139.7	144.0	525	354	1225	214
A 168.3 HC	9251155	26	83	168.3	215.0	525	354	1225	229
A 219.1 HC	9251165	70	83	219.1	360.0	650	409	1495	284
A 273.0 HC	9251175	108	83	273.0	575.0	750	480	1609	351
A 323.9 HC	9251185	150	83	323.9	810.0	850	634	2225	406

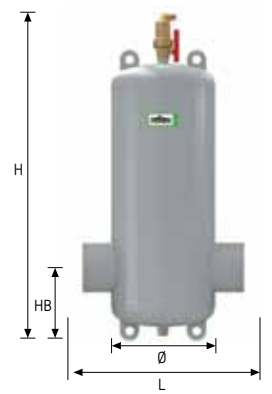

Steel, 110°C 10 bar
 • Flange connection

Type	Article No	Weight kg	Material Group	Connection	\dot{V} max m³/h	L mm	Ø D mm	H mm	HB mm
A 50 HC	9251305	11	83	DN 50/PN 16	25.0	350	132	810	153
A 65 HC	9251315	12	83	DN 65/PN 16	40.0	350	132	810	163
A 80 HC	9251325	18	83	DN 80/PN 16	54.0	470	206	965	159
A 100 HC	9251335	21	83	DN 100/PN 16	94.0	475	206	965	169
A 125 HC	9251345	60	83	DN 125/PN 16	144.0	635	354	1225	214
A 150 HC	9251355	64	83	DN 150/PN 16	215.0	635	354	1225	229
A 200 HC	9251365	90	83	DN 200/PN 16	360.0	775	409	1495	284
A 250 HC	9251375	146	83	DN 250/PN 16	575.0	890	480	1609	351
A 300 HC	9251385	194	83	DN 300/PN 16	810.0	1005	634	2225	406
A 350 HC	9251915	Upon request	83	DN 350/PN 16	1000.0	1128	634	2460	501
A 400 HC	9251925	Upon request	83	DN 400/PN 16	1300.0	1226	750	2740	580
A 450 HC	9251945	Upon request	83	DN 450/PN 16	1700.0	1330	750	3030	609
A 500 HC	9251955	Upon request	83	DN 500/PN 16	2120.0	1430	1000	3310	671
A 600 HC	9251965	Upon request	83	DN 600/PN 16	3000.0	1630	1200	3160	832



Benefits in brief

- Removes free circulating air and gas bubbles
- Functions in fully automated, continuous operation
- Produces just a minimal, constant drop in pressure
- Enables much faster hydraulic balancing after filling processes
- Prevents development of noise, wear through corrosion, and loss in performance through the formation of larger air bubbles
- Full range in terms of operating pressures, temperatures, and materials
- Specially designed for bigger systems with longer heights and higher volumetric flow

Exdirt

The core element is a tube mesh construction that has proven itself over the decades, with an extremely low rate of pressure loss in the flow direction and a high rate of pressure loss in the transverse direction. This drastically reduces the amount of turbulence and guides the sludge particles to a part-stabilized area

Volumetric flow:
1.25 - 8 m³/h

Exiso thermal insulation:
DN 20 - DN 40 and 2"

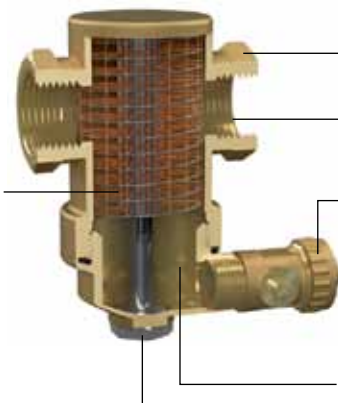

Magnetic insert
Suitable for -M models

Several connections are available from A22 to 2"

Through flow is not impeded by sludge

Space-saving, perpendicular draining tap. The collected sludge is quickly and forcefully pressed out when the tap is opened so that it can be closed again right away. The entire process takes just a few seconds

The capacity to capture large amounts of sludge results in longer intervals before cleaning becomes necessary

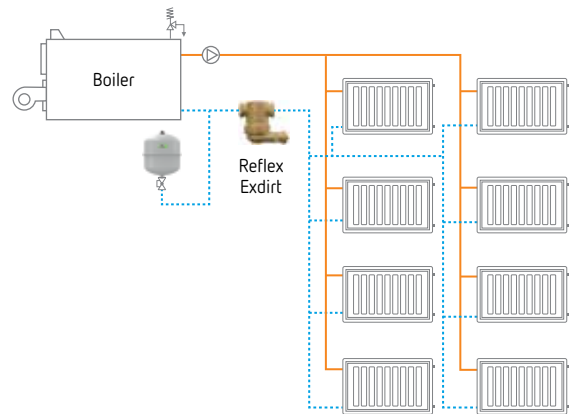

Exdirt "brass" system dirt and sludge separation sketch

Exdirt (Brass) Dirt and Sludge Separator

Brass, 110°C 10 bar
• Horizontal

Type	Article No	Weight kg	Material Group	Connection	\dot{V} max m ³ /h	L mm	Ø D mm	H mm
D 22	9252000	1.0	82	22 mm ¹⁾	1.25	85	63	103 ²⁾
D 3/4	9252010	0.9	82	G 3/4	1.25	85	63	103 ²⁾
D 1	9252020	1.0	82	G 1	2.00	88	63	120 ²⁾
D 1 1/4	9252030	1.2	82	G 1 1/4	3.70	88	63	140 ²⁾
D 1 1/2	9252040	1.3	82	G 1 1/2	5.00	88	63	174 ²⁾
D 2	9252050	3.1	82	G 2	8.00	132	100	215

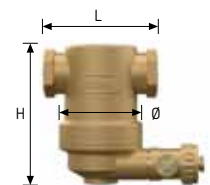

Brass, 110°C 10 bar
• Vertical

Type	Article No	Weight kg	Material Group	Connection	\dot{V} max m ³ /h	L mm	Ø D mm	H mm
D 22 V	9252500	1.5	82	22 mm ¹⁾	1.25	84	63	144 ²⁾
D 3/4 V	9252510	1.4	82	G 3/4	1.25	84	63	144 ²⁾
D 1 V	9252520	1.5	82	G 1	1.25	84	63	144 ²⁾

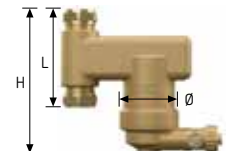

Exdirt (Brass) Dirt and Sludge Separator - with magnetic insert

Brass, 110°C 10 bar
• Horizontal M with magnetic insert

Type	Article No	Weight kg	Material Group	Connection	\dot{V} max m ³ /h	L mm	Ø D mm	H mm
D 22 M	9256000	1.1	82	22 mm ¹⁾	1.25	85	63	103 ²⁾
D 3/4 M	9256010	1.0	82	G 3/4	1.25	85	63	103 ²⁾
D 1 M	9256020	1.1	82	G 1	2.00	88	63	120 ²⁾
D 1 1/4 M	9256030	1.3	82	G 1 1/4	3.70	88	63	140 ²⁾
D 1 1/2 M	9256040	1.4	82	G 1 1/2	5.00	88	63	174 ²⁾
D 2 M	9256050	3.3	82	G 2	8.00	132	100	215

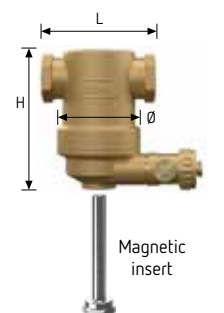

Brass, 110°C 10 bar
• Vertical M with magnetic insert

Type	Article No	Weight kg	Material Group	Connection	\dot{V} max m ³ /h	L mm	Ø D mm	H mm
D 22 V-M	9256500	1.6	82	22 mm ¹⁾	1.25	84	63	144 ²⁾
D 3/4 V-M	9256510	1.5	82	G 3/4	1.25	84	63	144 ²⁾
D 1 V-M	9256520	1.6	82	G 1	1.25	84	63	144 ²⁾

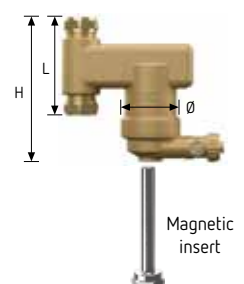

¹⁾ Clamping ring
²⁾ Thermal insulation available

Exdirt

The sludge/dirt separation in the Reflex Exdirt works on a similar principle to micro-bubble separation: The flow is guided through an area with a greater cross-section than the connection dimensions in order to reduce the flow speed. The ensuing turbulence caused by the tube mesh causes heavy materials to move in an undetermined direction. Depending on the volume flow, density, and volume, parts of these sludge particles are supported in their natural breakaway motion and guided to the bottom section of the casing

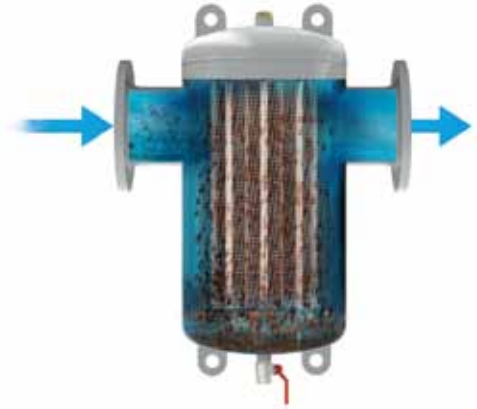
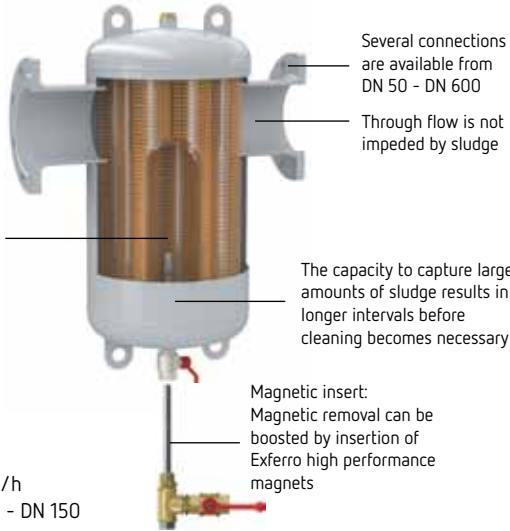

Exdirt Function Diagram

Overview

- Connection: DN 50 - DN 600
- Volumetric flow: 12.5 - 1530 m³/h
- Exiso thermal insulation: DN 50 - DN 150

Exdirt (Steel) Dirt and Sludge Separator

Steel, 110°C 10 bar

- Welded connection

Type	Article No	Weight kg	Material Group	Connection	\dot{V} max m ³ /h	L mm	Ø D mm	H mm	HB mm
D 60.3	8252100	5	83	60.3	12.5	260	132	521 ¹⁾	370
D 76.1	8252110	5	83	76.1	20.0	260	132	521 ¹⁾	370
D 88.9	8252120	11	83	88.9	27.0	370	206	636 ¹⁾	370
D 114.3	8252130	11	83	114.3	47.0	370	206	636 ¹⁾	370
D 139.7	8252140	24	83	139.7	72.0	525	354	811 ¹⁾	430
D 168.3	8252150	26	83	168.3	108.0	525	354	811 ¹⁾	430
D 219.1	8252160	90	83	219.1	180.0	650	409	1021	430
D 273.0	8252170	108	83	273.0	288.0	750	480	1324	500
D 323.9	8252180	150	83	323.9	405.0	850	634	1535	500

¹⁾ Thermal insulation available

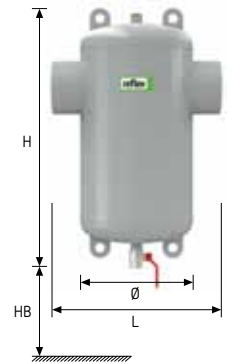

Steel, 110°C 10 bar

- Flange connection

Type	Article No	Weight kg	Material Group	Connection	\dot{V} max m ³ /h	L mm	Ø D mm	H mm	HB mm
D 50	8252300	11	83	DN 50/PN 16	12.5	350	132	521 ¹⁾	370
D 65	8252310	12	83	DN 65/PN 16	20.0	350	132	521 ¹⁾	370
D 80	8252320	18	83	DN 80/PN 16	27.0	470	206	636 ¹⁾	370
D 100	8252330	21	83	DN 100/PN 16	47.0	470	206	636 ¹⁾	370
D 125	8252340	60	83	DN 125/PN 16	72.0	635	354	811 ¹⁾	430
D 150	8252350	64	83	DN 150/PN 16	108.0	635	354	811 ¹⁾	430
D 200	8252360	110	83	DN 200/PN 16	180.0	775	409	1021	430
D 250	8252370	146	83	DN 250/PN 16	288.0	890	480	1324	500
D 300	8252380	194	83	DN 300/PN 16	405.0	1005	634	1535	500
D 350	8252910	Upon request	83	DN 350/PN 16	500.0	1128	634	1890	600
D 400	8252920	Upon request	83	DN 400/PN 16	650.0	1226	750	2090	600
D 450	8252940	Upon request	83	DN 450/PN 16	850.0	1330	750	2300	600
D 500	8252950	Upon request	83	DN 500/PN 16	1060.0	1430	1000	2520	600
D 600	8252960	Upon request	83	DN 600/PN 16	1530.0	1630	1200	2960	600

¹⁾ Thermal insulation available

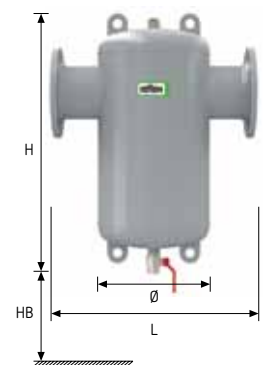

Benefits in brief:

- Removes free circulating dirt and sludge particles < 5 micrometer
- Functions in fully automated continuous operation, produces just a minimal constant drop in pressure
- Maintenance takes just 5 seconds Permanent free throughflow opening for the water
- No shut-off valves or bypass lines required. Desludging possible during system operation
- Full range in terms of operating pressures and materials
- Continually ensures flawless functionality of heat generators, thermostat valves, etc.
- Reduces the risk of system defects and breakdowns in the long term

Exdirt R

The sludge/dirt separation in the Reflex Exdirt R works on a similar principle to micro-bubble separation: The flow is guided through an area with a greater cross-section than the connection dimensions in order to reduce the flow speed. The ensuing turbulence caused by the tube mesh causes heavy materials to move in an undetermined direction. Depending on the volume flow, density, and volume, parts of these sludge particles are supported in their natural breakaway motion and guided to the bottom section of the casing

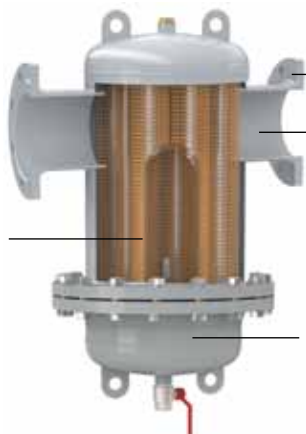

Several connections are available from DN 50 - DN 600
Through flow is not impeded by sludge

The capacity to capture large amounts of sludge results in longer intervals before cleaning becomes necessary. Maintenance is much easier with its detachable base

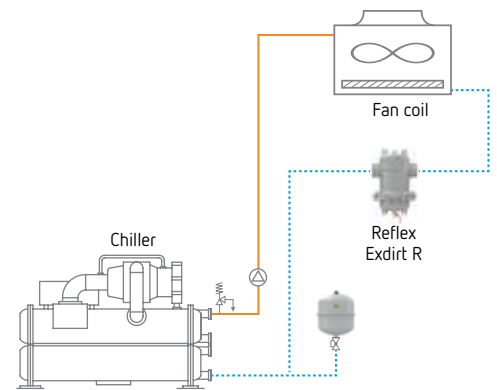

Exdirt "steel" system dirt and sludge separation sketch

Overview

- Connection: DN 50 - DN 600
- Volumetric flow: 12.5 - 1530 m³/h

Exdirt (Steel) Dirt and Sludge Separator - with inspection flange

Steel, 110°C 10 bar

- Welded connection, inspection flange

Type	Article No	Weight kg	Material Group	Connection	\dot{V} max m ³ /h	L mm	Ø D mm	H mm	HB mm
D 60.3 R	8252200	18	83	60,3	12,5	260	132	521 ¹⁾	370
D 76.1 R	8252210	19	83	76,1	20,0	260	132	521 ¹⁾	370
D 88.9 R	8252220	57	83	88,9	27,0	370	206	636 ¹⁾	430
D 114.3 R	8252230	70	83	114,3	47,0	370	206	636 ¹⁾	430
D 139.7 R	8252240	120	83	139,7	72,0	525	354	811 ¹⁾	550
D 168.3 R	8252250	125	83	168,3	108,0	525	354	811 ¹⁾	550
D 219.1 R	8252260	140	83	219,1	180,0	650	409	1021	650
D 273.0 R	8252270	196	83	273,0	288,0	750	480	1324	850
D 323.9 R	8252280	277	83	323,9	405,0	850	634	1535	1000

¹⁾ Thermal insulation available

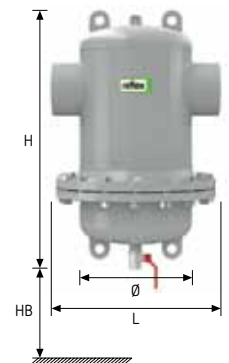

Steel, 110°C 10 bar

- Flange connection, inspection flange

Type	Article No	Weight kg	Material Group	Connection	\dot{V} max m ³ /h	L mm	Ø D mm	H mm	HB mm
D 50 R	8252400	20	83	DN 50/PN 16	12,5	350	132	521 ¹⁾	370
D 65 R	8252410	21	83	DN 65/PN 16	20,0	350	132	521 ¹⁾	370
D 80 R	8252420	68	83	DN 80/PN 16	27,0	470	206	636 ¹⁾	430
D 100 R	8252430	76	83	DN 100/PN 16	47,0	475	206	636 ¹⁾	430
D 125 R	8252440	120	83	DN 125/PN 16	72,0	635	354	811 ¹⁾	550
D 150 R	8252450	140	83	DN 150/PN 16	108,0	635	354	811 ¹⁾	550
D 200 R	8252460	181	83	DN 200/PN 16	180,0	775	409	1021	650
D 250 R	8252470	220	83	DN 250/PN 16	288,0	890	480	1324	850
D 300 R	8252480	305	83	DN 300/PN 16	405,0	1005	634	1535	1000
D 350 R	8252912	Upon request	83	DN 350/PN 16	500,0	1128	634	1890	Upon request
D 400 R	8252922	Upon request	83	DN 400/PN 16	650,0	1226	750	2090	Upon request
D 450 R	8252942	Upon request	83	DN 450/PN 16	850,0	1330	750	2300	Upon request
D 500 R	8252952	Upon request	83	DN 500/PN 16	1060,0	1430	1000	2520	Upon request
D 600 R	8252962	Upon request	83	DN 600/PN 16	1530,0	1630	1200	2960	Upon request

¹⁾ Thermal insulation available

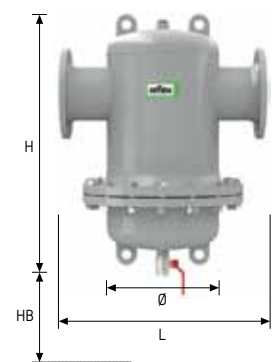

Benefits in brief:

- Removes free circulating dirt and sludge particles < 5 micrometer
- Functions in fully automated continuous operation, produces just a minimal constant drop in pressure
- Maintenance takes just 5 seconds Permanent free throughflow opening for the water
- No shut-off valves or bypass lines required. Desludging possible during system operation
- Full range in terms of operating pressures and materials
- Continually ensures flawless functionality of heat generators, thermostat valves, etc.
- Reduces the risk of system defects and breakdowns in the long term
- Easier maintenance due to detachable base

Exdirt HC

The sludge/dirt separation in the Reflex Exdirt HC works on a similar principle to micro-bubble separation: The flow is guided through an area with a greater cross-section than the connection dimensions in order to reduce the flow speed. The ensuing turbulence caused by the tube mesh causes heavy materials to move in an undetermined direction. Depending on the volume flow, density, and volume, parts of these sludge particles are supported in their natural breakaway motion and guided to the bottom section of the casing. Specially designed for bigger systems with longer heights and higher volumetric flow.

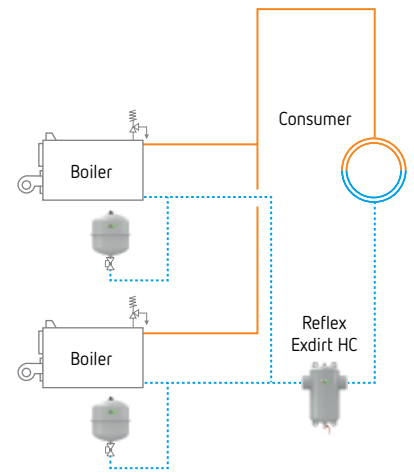
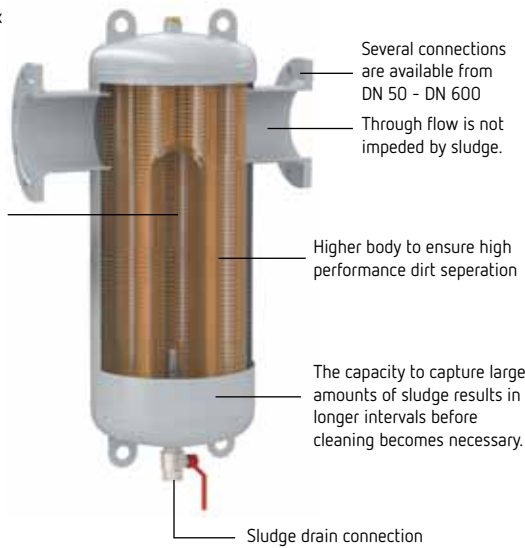

Exdirt "steel" HiCap system dirt and sludge separation sketch

Overview

- Connection: DN 50 - DN 600
- Volumetric flow: 25 - 3000 m³/h

Exdirt HiCap (Steel) Dirt and Sludge Separator

Steel, 110°C 10 bar

- Welded connection

Type	Article No	Weight kg	Material Group	Connection	\dot{V} max m ³ /h	L mm	Ø D mm	H mm	HB mm
D 60.3 HC	8252105	5	83	60.3	25.0	260	132	706	430
D 76.1 HC	8252115	5	83	76.1	40.0	260	132	706	430
D 88.9 HC	8252125	11	83	88.9	54.0	370	206	861	430
D 114.3 HC	8252135	11	83	114.3	94.0	370	206	861	430
D 139.7 HC	8252145	24	83	139.7	144.0	525	354	1121	500
D 168.3 HC	8252155	26	83	168.3	215.0	525	354	1121	500
D 219.1 HC	8252165	90	83	219.1	360.0	650	409	1391	500
D 273.0 HC	8252175	108	83	273.0	575.0	750	480	1532	600
D 323.9 HC	8252185	150	83	323.9	810.0	850	634	2148	600

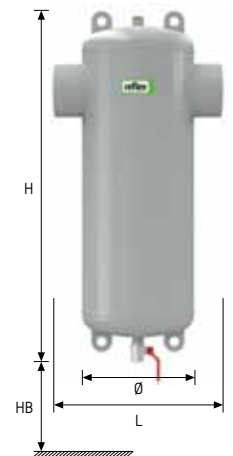

Steel, 110°C 10 bar

- Flange connection

Type	Article No	Weight kg	Material Group	Connection	\dot{V} max m ³ /h	L mm	Ø D mm	H mm	HB mm
D 50 HC	8252305	11	83	DN 50/PN 16	25.0	350	132	706 ¹⁾	430
D 65 HC	8252315	12	83	DN 65/PN 16	40.0	350	132	706 ¹⁾	430
D 80 HC	8252325	18	83	DN 80/PN 16	54.0	470	206	861 ¹⁾	430
D 100 HC	8252335	21	83	DN 100/PN 16	94.0	470	206	861 ¹⁾	430
D 125 HC	8252345	60	83	DN 125/PN 16	144.0	635	354	1121 ¹⁾	500
D 150 HC	8252355	64	83	DN 150/PN 16	215.0	635	354	1121 ¹⁾	500
D 200 HC	8252365	110	83	DN 200/PN 16	360.0	775	409	1391	500
D 250 HC	8252375	146	83	DN 250/PN 16	575.0	890	480	1532	600
D 300 HC	8252385	194	83	DN 300/PN 16	810.0	1005	634	2148	600
D 350 HC	8252915	273	83	DN 350/PN 16	1000.0	1128	634	2400	700
D 400 HC	8252925	354	83	DN 400/PN 16	1300.0	1226	750	2680	700
D 450 HC	8252945	467	83	DN 450/PN 16	1700.0	1330	750	2970	700
D 500 HC	8252955	701	83	DN 500/PN 16	2120.0	1430	1000	3100	700
D 600 HC	8252965	913	83	DN 600/PN 16	3000.0	1630	1200	3250	700



Exdirt R-HC

The sludge/dirt separation in the Reflex Exdirt R - HC works on a similar principle to micro-bubble separation: The flow is guided through an area with a greater cross-section than the connection dimensions in order to reduce the flow speed. The ensuing turbulence caused by the tube mesh causes heavy materials to move in an undetermined direction. Depending on the volume flow, density, and volume, parts of these sludge particles are supported in their natural breakaway motion and guided to the bottom section of the casing. Specially designed for bigger systems with longer heights and higher volumetric flow

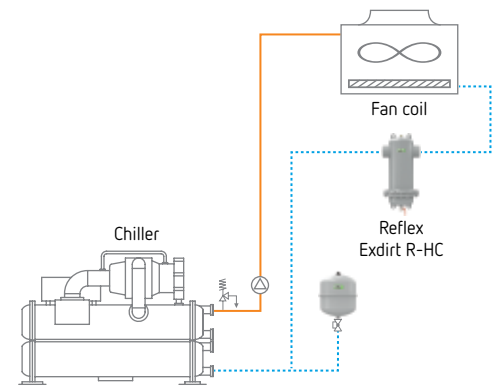
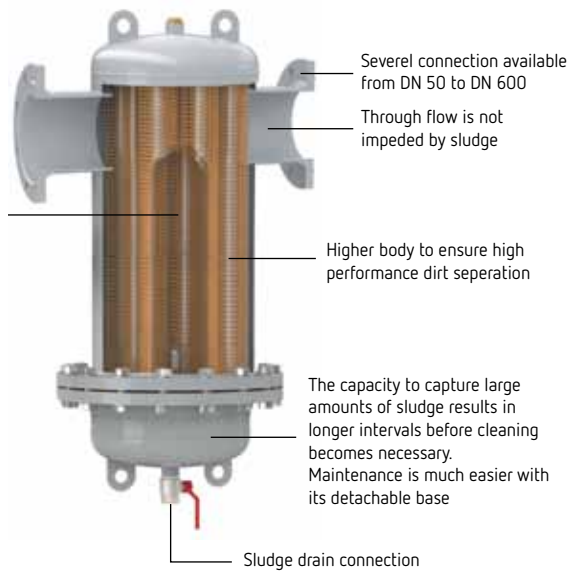

Exdirt "steel" HiCap system with inspection flange dirt and sludge separation sketch

Overview

- Connection: DN 50 - DN 600
- Volumetric flow: 12.5 - 1530 m³/h

Exdirt HiCap (Steel) Dirt and Sludge Separator - with inspection flange

Steel, 110°C 10 bar

- Welded connection, inspection flange

Type	Article No	Weight kg	Material Group	Connection	\dot{V} max m ³ /h	L mm	Ø D mm	H mm	HB mm
D 60.3 R-HC	8252205	18	83	60.3	25.0	260	132	706	570
D 76.1 R-HC	8252215	19	83	76.1	40.0	260	132	706	570
D 88.9 R-HC	8252225	57	83	88.9	54.0	370	206	861	660
D 114.3 R-HC	8252235	70	83	114.3	94.0	370	206	861	660
D 139.7 R-HC	8252245	120	83	139.7	144.0	525	354	1121	870
D 168.3 R-HC	8252255	125	83	168.3	215.0	525	354	1121	870
D 219.1 R-HC	8252265	140	83	219.1	360.0	650	409	1391	1030
D 273.0 R-HC	8252275	196	83	273.0	575.0	750	480	1532	1050
D 323.9 R-HC	8252285	277	83	323.9	810.0	850	634	2148	1600

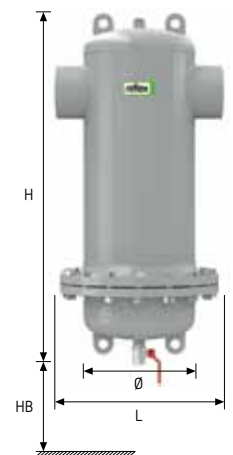

Steel, 110°C 10 bar

- Flange connection, inspection flange

Type	Article No	Weight kg	Material Group	Connection	\dot{V} max m ³ /h	L mm	Ø D mm	H mm	HB mm
D 50 R-HC	8252405	20	83	DN 50/PN 16	25.0	350	132	706	570
D 65 R-HC	8252415	21	83	DN 65/PN 16	40.0	350	132	706	570
D 80 R-HC	8252425	68	83	DN 80/PN 16	54.0	470	206	861	660
D 100 R-HC	8252435	76	83	DN 100/PN 16	94.0	475	206	861	660
D 125 R-HC	8252445	120	83	DN 125/PN 16	144.0	635	354	1121	870
D 150 R-HC	8252455	140	83	DN 150/PN 16	215.0	635	354	1121	870
D 200 R-HC	8252465	181	83	DN 200/PN 16	360.0	775	409	1391	1030
D 250 R-HC	8252475	220	83	DN 250/PN 16	575.0	890	480	1532	1050
D 300 R-HC	8252485	305	83	DN 300/PN 16	810.0	1005	634	2148	1600
D 350 R-HC	8252917	Upon request	83	DN 350/PN 16	1000.0	1128	634	2400	Upon request
D 400 R-HC	8252927	Upon request	83	DN 400/PN 16	1300.0	1226	750	2680	Upon request
D 450 R-HC	8252947	Upon request	83	DN 450/PN 16	1700.0	1330	750	2970	Upon request
D 500 R-HC	8252957	Upon request	83	DN 500/PN 16	2120.0	1430	1000	3100	Upon request
D 600 R-HC	8252967	Upon request	83	DN 600/PN 16	3000.0	1630	1200	3250	Upon request



Extwin

The core element is a tube mesh construction that has proven itself over the decades, with an extremely low rate of pressure loss in the flow direction and a high rate of pressure loss in the transverse direction. This drastically reduces the amount of turbulence and guides the sludge particles to a part-stabilized area

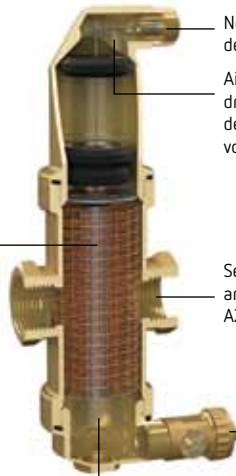

Non-leak, non-shut-off deaeration valve
Air chamber with special design: driving impurities do not reach the deaeration valve; high air chamber volume to counteract pressure fluctuations

Several connections are available from A22 to 1"

The capacity to capture large amounts of sludge results in longer intervals before cleaning becomes necessary

Space-saving, perpendicular draining tap. The collected sludge is quickly and forcefully pressed out when the tap is opened so that it can be closed again right away. The entire process takes just a few seconds

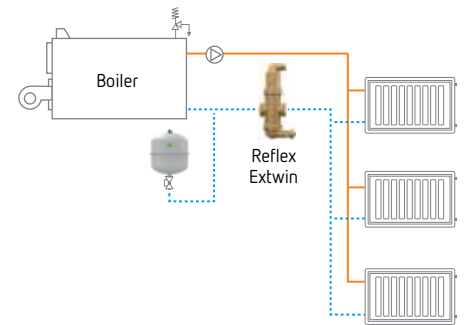

Extwin "brass" system combined micro-bubble, dirt and sludge separation sketch

Overview

- Dimension-dependent brass designs
- Installation: horizontal, vertical
- Connection options: thread and clamping ring,
- Connection diameter A22 - 1"
- Max. operating pressure: 10 bar
- Max. operating temperature 110°C

Benefits in brief

- Removes free circulating dirt and sludge particles
- Functions in fully automated continuous operation
- Maintenance takes just 5 seconds
- Permanent free throughflow opening for the water
- No shut-off valves or bypass lines required. Desludging possible during system operation
- Full range in terms of operating pressures and materials
- Continually ensures flawless functionality of heat generators, thermostat valves, etc.
- Reduces the risk of system defects and breakdowns in the long term

Extwin (Brass) Combined Micro-Bubble, Dirt, and Sludge Separator

Brass, 110°C 10 bar

• Horizontal

Type	Article No	Weight kg	Material Group	Connection	\dot{V}_{max} m ³ /h	L mm	Ø D mm	H mm
TW 22	9253000	1,7	82	22 mm ¹⁾	1.25	105	63	261
TW 1	9253010	1,7	82	G 1	2.00	84	63	261

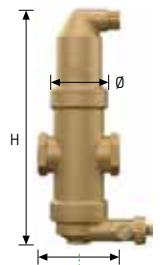

Brass, 110°C 10 bar

• Horizontal M with magnetic insert

Type	Article No	Weight kg	Material Group	Connection	\dot{V}_{max} m ³ /h	L mm	Ø D mm	H mm
TW 22 M	9257000	1,8	82	22 mm ¹⁾	1.25	105	63	261
TW 1 M	9257010	1,8	82	G 1	2.00	84	63	261



Brass, 110°C 10 bar

• Vertical

Type	Article No	Weight kg	Material Group	Connection	\dot{V}_{max} m ³ /h	L mm	Ø D mm	H mm
TW 22 V	9253500	2,1	82	22 mm ¹⁾	1.25	105	63	261

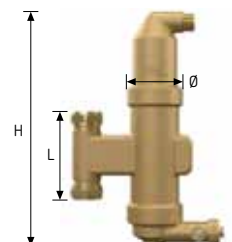

Brass, 110°C 10 bar

• Vertical M with magnetic insert

Type	Article No	Weight kg	Material Group	Connection	\dot{V}_{max} m ³ /h	L mm	Ø D mm	H mm
TW 22 V-M	9257500	2,2	82	22 mm ¹⁾	1.25	105	63	261



Extwin

The Reflex Extwin combines the modes of operation of the Exvoid and Exdirt, the principle corresponding with the functionality set out on

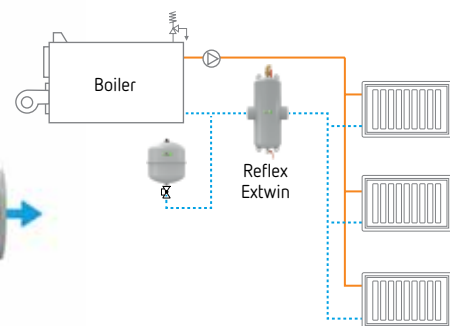
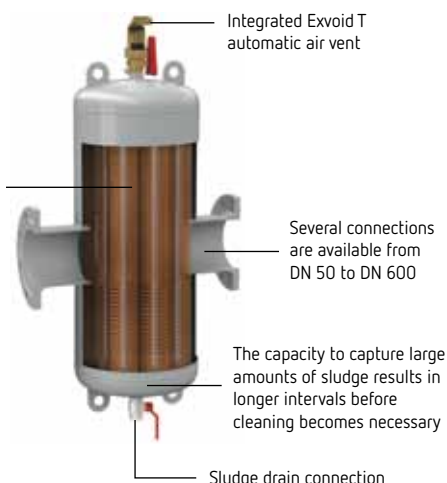

Extwin "Steel" system with combined micro-bubble dirt and sludge separation sketch

Overview

- Connection: DN 50 - DN 600
- Volumetric flow: 12.5-405 m³/h
- Exiso thermal insulation: DN 50 - DN 125

Extwin (Steel) Combined Micro-Bubble, Dirt, and Sludge Separator

Steel, 110°C 10 bar

- Welded connection

Type	Article No	Weight kg	Material Group	Connection	\dot{V} max m ³ /h	L mm	Ø D mm	H mm	HB mm
TW 60.3	8253100	7	83	60,3	12,5	260	132	785	370
TW 76.1	8253110	8	83	76,1	20,0	260	132	785	370
TW 88.9	8253120	15	83	88,9	27,0	370	206	940	370
TW 114.3	8253130	17	83	114,3	47,0	370	206	940	370
TW 139.7	8253140	32	83	139,7	72,0	525	354	1200	430
TW 168.3	8253150	40	83	168,3	108,0	525	354	1200	430
TW 219.1	8253160	92	83	219,1	180,0	650	409	1470	430
TW 273.0	8253170	196	83	273,0	288,0	750	480	1916	500
TW 323.9	8253180	266	83	323,9	405,0	850	634	2237	500

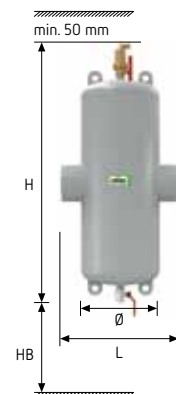

Steel, 110°C 10 bar

- Flange connection

Type	Article No	Weight kg	Material Group	Connection	\dot{V} max m ³ /h	L mm	Ø D mm	H mm	HB mm
TW 50	8253300	13	83	DN 50/PN 16	12.5	350	132	785	370
TW 65	8253310	13	83	DN 65/PN 16	20.0	350	132	785	370
TW 80	8253320	37	83	DN 80/PN 16	27.0	470	206	940	370
TW 100	8253330	43	83	DN 100/PN 16	47.0	475	206	940	370
TW 125	8253340	70	83	DN 125/PN 16	72.0	635	354	1200	430
TW 150	8253350	75	83	DN 150/PN 16	108.0	635	354	1200	430
TW 200	8253360	108	83	DN 200/PN 16	180.0	775	409	1470	430
TW 250	8253370	230	83	DN 250/PN 16	288.0	890	480	1916	500
TW 300	8253380	300	83	DN 300/PN 16	405.0	1005	634	2237	500
TW 350	8253910	Upon request	83	DN 350/PN 16	500.0	1128	634	2600	600
TW 400	8253920	Upon request	83	DN 400/PN 16	650.0	1226	750	2900	600
TW 450	8253940	Upon request	83	DN 450/PN 16	850.0	1330	750	3150	600
TW 500	8253950	Upon request	83	DN 500/PN 16	1060.0	1430	1000	3500	600
TW 600	8253960	Upon request	83	DN 600/PN 16	1530.0	1630	1200	4100	600

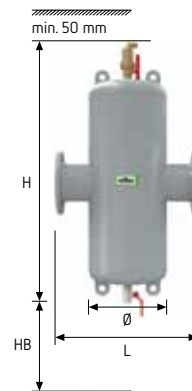

Benefits in brief

- Combines the protective functions of Reflex Exvoid and Exdirt in a single component in chilled water systems
- Single installation, doubled effect
- A far more cost-effective solution than using both the individual components
- Full range in terms of operating pressures and materials

Extwin R

The reflex Extwin combines the modes of operation of the Exvoid and Exdirt, the principle corresponding with the functionality set out on pages 18 & 21

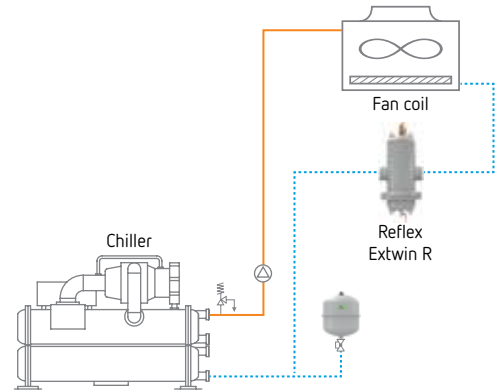
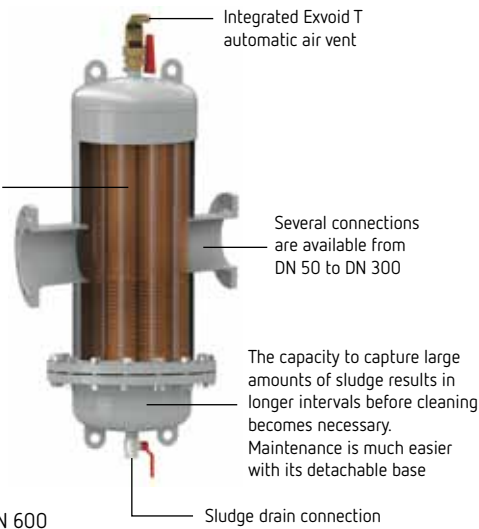

Extwin "Steel" system with inspection flange combined micro-bubble, dirt and sludge separation sketch

Overview

- Connection: DN 50 - DN 600
- Volumetric flow: 12.5 - 1530 m³/h
- Exiso thermal insulation: DN 50 - DN 125

Extwin (Steel) Combined Micro-Bubble, Dirt, and Sludge Separator - with inspection flange

Steel, 110°C 10 bar

- Welded connection, inspection flange

Type	Article No	Weight kg	Material Group	Connection	\dot{V} max m ³ /h	L mm	Ø D mm	H mm	HB mm
TW 60.3 R	8253200	16	83	60,3	12,5	350	132	785	370
TW 76.1 R	8253210	16	83	76,1	20,0	350	132	785	370
TW 88.9 R	8253220	50	83	88,9	27,0	470	206	940	550
TW 114.3 R	8253230	65	83	114,3	47,0	475	206	940	550
TW 139.7 R	8253240	102	83	139,7	72,0	635	354	1200	750
TW 168.3 R	8253250	110	83	168,3	108,0	635	354	1200	750
TW 219.1 R	8253260	180	83	219,1	180,0	775	409	1470	1000
TW 273.0 R	8253270	219	83	273,0	288,0	890	480	1916	1350
TW 323.9 R	8253280	320	83	323,9	405,0	1005	634	2237	1850

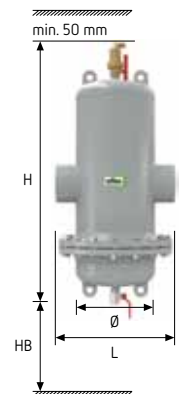

Steel, 110°C 10 bar

- Flange connection, inspection flange

Type	Article No	Weight kg	Material Group	Connection	\dot{V} max m ³ /h	L mm	Ø D mm	H mm	HB mm
TW 50	8253300	13	83	DN 50/PN 16	12.5	350	132	785	370
TW 65	8253310	13	83	DN 65/PN 16	20.0	350	132	785	370
TW 80	8253320	37	83	DN 80/PN 16	27.0	470	206	940	550
TW 100	8253330	43	83	DN 100/PN 16	47.0	475	206	940	550
TW 125	8253340	70	83	DN 125/PN 16	72.0	635	354	1200	750
TW 150	8253350	75	83	DN 150/PN 16	108.0	635	354	1200	750
TW 200	8253360	108	83	DN 200/PN 16	180.0	775	409	1470	1000
TW 250	8253370	230	83	DN 250/PN 16	288.0	890	480	1916	1350
TW 300	8253380	300	83	DN 300/PN 16	405.0	1005	634	2237	1850
TW 350	8253910	Upon request	83	DN 350/PN 16	500.0	1128	634	2600	Upon request
TW 400	8253920	Upon request	83	DN 400/PN 16	650.0	1226	750	2900	Upon request
TW 450	8253940	Upon request	83	DN 450/PN 16	850.0	1330	750	3150	Upon request
TW 500	8253950	Upon request	83	DN 500/PN 16	1060.0	1430	1000	3500	Upon request
TW 600	8253960	Upon request	83	DN 600/PN 16	1530.0	1630	1200	4100	Upon request



Benefits in brief

- Combines the protective functions of Reflex Exvoid and Exdirt in a single component in chilled water systems
- Single installation, doubled effect
- A far more cost-effective solution than using both the individual components
- Full range in terms of operating pressures and materials
- Easier maintenance due to detachable base

Extwin HC

The Reflex Extwin HC combines the modes of operation of the Exvoid and Exdirt, the principle corresponding with the functionality set out on pages 18 & 21 Specially designed for bigger systems with longer heights and higher volumetric flow.

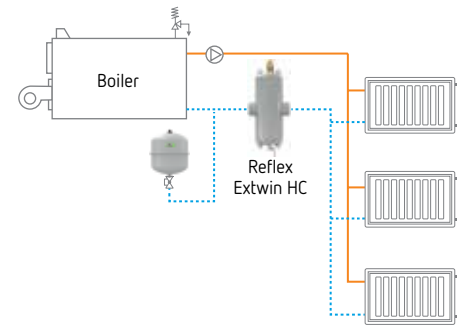
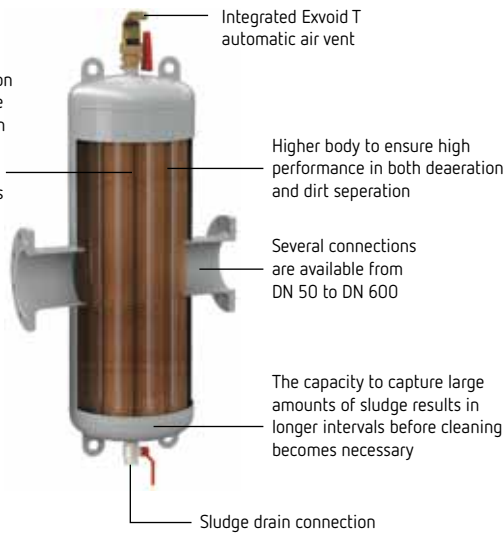

Extwin "Steel" HiCap system combined micro-bubble, dirt and sludge separation sketch

Overview

- Connection: DN 50 - DN 600
- Volumetric flow: 25 - 3000 m³/h

Extwin HiCap (Steel) Combined Micro-Bubble, Dirt, and Sludge Separator

Steel, 110°C 10 bar
 • Welded connection

Type	Article No	Weight kg	Material Group	Connection	\dot{V} max m ³ /h	L mm	Ø D mm	H mm	HB mm
TW 60.3 HC	8252105	Upon request	83	60,3	25.0	260	132	1050	430
TW 76.1 HC	8252115	Upon request	83	76,1	40.0	260	132	1050	430
TW 88.9 HC	8252125	Upon request	83	88,9	54.0	370	206	1285	430
TW 114.3 HC	8252135	Upon request	83	114,3	94.0	370	206	1285	430
TW 139.7 HC	8252145	Upon request	83	139,7	144.0	525	354	1710	500
TW 168.3 HC	8252155	Upon request	83	168,3	215.0	525	354	1710	500
TW 219.1 HC	8252165	Upon request	83	219,1	360.0	650	409	2035	500
TW 273.0 HC	8252175	Upon request	83	273,0	575.0	750	480	2764	600
TW 323.9 HC	8252185	Upon request	83	323,9	810.0	850	634	3330	600

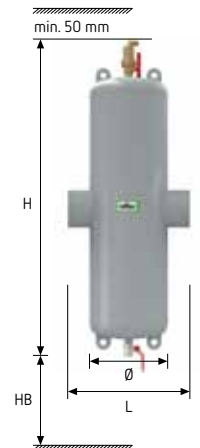

Steel, 110°C 10 bar
 • Flange collection

Type	Article No	Weight kg	Material Group	Connection	\dot{V} max m ³ /h	L mm	Ø D mm	H mm	HB mm
TW 50 HC	8253305	13	83	DN 50/PN 16	25.0	350	132	1050	430
TW 65 HC	8253315	13	83	DN 65/PN 16	40.0	350	132	1050	430
TW 80 HC	8253325	37	83	DN 80/PN 16	54.0	470	206	1285	430
TW 100 HC	8253335	43	83	DN 100/PN 16	94.0	475	206	1285	430
TW 125 HC	8253345	70	83	DN 125/PN 16	144.0	635	354	1710	500
TW 150 HC	8253355	75	83	DN 150/PN 16	215.0	635	354	1710	500
TW 200 HC	8253365	108	83	DN 200/PN 16	360.0	775	409	2035	500
TW 250 HC	8253375	230	83	DN 250/PN 16	575.0	890	480	2764	600
TW 300 HC	8253385	300	83	DN 300/PN 16	810.0	1005	634	3330	600
TW 350 HC	8253915	331	83	DN 350/PN 16	1000.0	1128	634	3600	700
TW 400 HC	8253925	429	83	DN 400/PN 16	1300.0	1226	750	4000	700
TW 450 HC	8253945	573	83	DN 450/PN 16	1700.0	1330	750	4500	700
TW 500 HC	8253955	853	83	DN 500/PN 16	2120.0	1430	1000	4900	700
TW 600 HC	8253965	1217	83	DN 600/PN 16	3000.0	1630	1200	5800	700

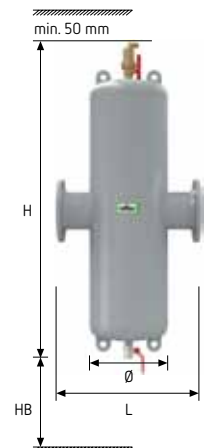

Benefits in brief

- Combines the protective functions of Reflex Exvoid and Exdirt in a single component in chilled water systems
- Single installation, doubled effect
- A far more cost-effective solution than using both the individual components
- Full range in terms of operating pressures and materials
- Specially designed for bigger systems with longer heights and higher volumetric flow

Extwin R-HC

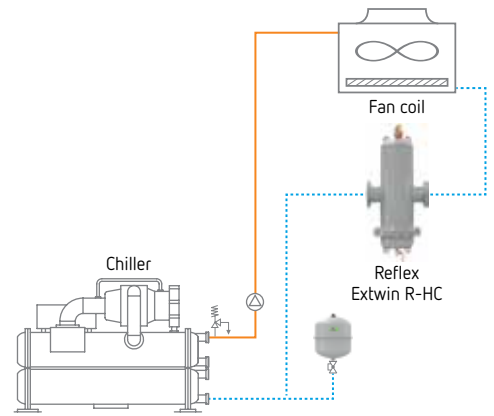
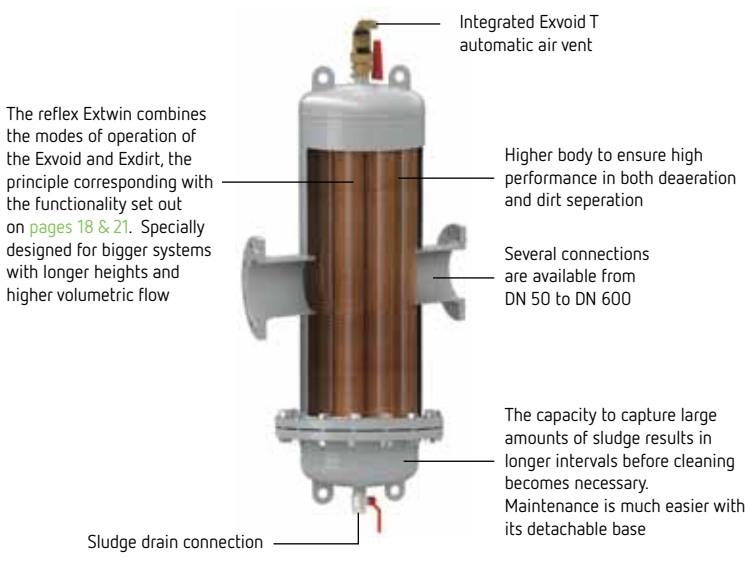

Extwin "Steel" HiCap with inspection opening system combined micro-bubble, dirt and sludge separation sketch

Extwin HiCap (Steel) Combined Micro-Bubble, Dirt, and Sludge Separator - with inspection opening

Steel, 110°C 10 bar
 • Welded connection, inspection flange

Type	Article No	Weight kg	Material Group	Connection	\dot{V} max m ³ /h	L mm	Ø D mm	H mm	HB mm
TW 60.3 R-HC	8253205	16	83	60.3	25.0	260	132	1050	640
TW 76.1 R-HC	8253215	16	83	76.1	40.0	260	132	1050	640
TW 88.9 R-HC	8253225	50	83	88.9	54.0	370	206	1285	900
TW 114.3 R-HC	8253235	65	83	114.3	94.0	370	206	1285	900
TW 139.7 R-HC	8253245	102	83	139.7	144.0	525	354	1710	1300
TW 168.3 R-HC	8253255	110	83	168.3	215.0	525	354	1710	1300
TW 219.1 R-HC	8253265	180	83	219.1	360.0	650	409	2035	1600
TW 273.0 R-HC	8253275	219	83	273.0	575.0	750	480	2764	2100
TW 323.9 R-HC	8253285	320	83	323.9	810.0	850	634	3330	2900

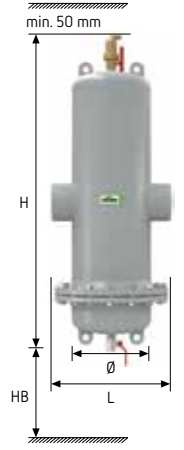

Steel, 110°C 10 bar
 • Flange connection, inspection flange

Type	Article No	Weight kg	Material Group	Connection	\dot{V} max m ³ /h	L mm	Ø D mm	H mm	HB mm
TW 50 R-HC	8253405	21	83	DN 50/PN 16	25.0	350	132	1050	640
TW 65 R-HC	8253415	22	83	DN 65/PN 16	40.0	350	132	1050	640
TW 80 R-HC	8253425	71	83	DN 80/PN 16	54.0	470	206	1285	900
TW 100 R-HC	8253435	78	83	DN 100/PN 16	94.0	475	206	1285	900
TW 125 R-HC	8253445	114	83	DN 125/PN 16	144.0	635	354	1710	1300
TW 150 R-HC	8253455	120	83	DN 150/PN 16	215.0	635	354	1710	1300
TW 200 R-HC	8253465	200	83	DN 200/PN 16	360.0	775	409	2035	1600
TW 250 R-HC	8253475	235	83	DN 250/PN 16	575.0	890	480	2764	2100
TW 300 R-HC	8253485	340	83	DN 300/PN 16	810.0	1005	634	3330	2900
TW 350 R-HC	8253917	Upon request	83	DN 350/PN 16	1000.0	1128	634	3600	Upon request
TW 400 R-HC	8253927	Upon request	83	DN 400/PN 16	1300.0	1226	750	4000	Upon request
TW 450 R-HC	8253947	Upon request	83	DN 450/PN 16	1700.0	1330	750	4500	Upon request
TW 500 R-HC	8253957	Upon request	83	DN 500/PN 16	2120.0	1430	1000	4900	Upon request
TW 600 R-HC	8253967	Upon request	83	DN 600/PN 16	3000.0	1630	1200	5800	Upon request



Benefits in brief

- Combines the protective functions of Reflex Exvoid and Exdirt in a single component in chilled water systems
- Single installation, doubled effect
- A far more cost-effective solution than using both the individual components
- Full range in terms of operating pressures and materials
- Specially designed for bigger systems with longer heights and higher volumetric flow
- Easier maintenance due to detachable base

Reflex EB Dirt Collector

- Separates and collects dirt (magnetite, welding grid, sand etc.) from the systemwater
- Protects and improves average lifetime of components (pumps, valves, heat exchangers etc.)
- Minimum pressure drop
- Meets or exceeds EC norms for pressure vessels 97/23/EC
- Durable epoxy coating with attractive new colour

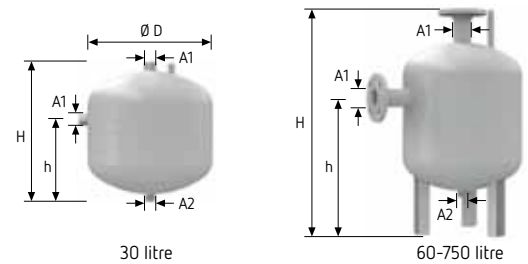

CE

		Type 6 Bar / 120°C	Article No	Material Group	Ø D mm	H mm	h mm	A1	A2
6 bar 120°C		EB 180	8632000	25	600	1110	726	DN 100/PN 6	R 1
		EB 300	8633000	25	600	1600	1141	DN 125/PN 6	R 1
		EB 400	8634000	25	750	1500	1027	DN 150/PN 6	R 1
		EB 750	8634100	25	750	2215	1677	DN 250/PN 6	R 1
		Type 10 Bar / 120°C	Article No	Material Group	Ø D mm	H mm	h mm	A1	A2
10 bar 120°C		EB 30	8636000	25	409	455	270	R 1 1/4	R 1
		EB 60	8635100	25	409	770	465	DN 50/PN 16	R 1
		EB 80	8636200	25	480	765	468	DN 65/PN 16	R 1
		EB 100	8636300	25	480	870	535	DN 80/PN 16	R 1

Reflex LA Air Separator

- Separates gas bubbles (air, nitrogen etc.) from heating and cooling systems
- Increases system efficiency and average lifetime of components
- Minimum pressure drop
- Most suitable for rooftop plantrooms at low pressure
- Welded collection
- Durable epoxy coating with attractive new colour

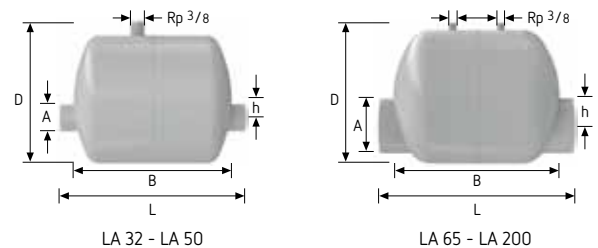

LA 32 - LA 50

LA 65 - LA 200

		Type 10 Bar / 120°C	Article No	Material Group	L mm	Ø D mm	H mm	A
10 bar 120°C		LA 32	8671000	72	300	30	206	DN 32
		LA 40	8672000	72	300	40	206	DN 40
		LA 50	8673000	72	300	40	206	DN 50
		LA 65	8674000	72	390	60	280	DN 65
		LA 80	8675000	72	390	60	280	DN 80
		LA 100	8676000	72	390	50	280	DN 100
		LA 125	8677000	72	390	40	280	DN 125
		LA 150	8678000	72	590	90	409	DN 150
		LA 200	8679000	72	590	40	409	DN 200

Reflex T Expansion Trap

- Separates water from steam in heating installation $\geq 100^\circ\text{C}$
- To be connected to the safety valve according to DIN EN 12828
- Allows evaporation without danger to the ambience
- Durable epoxy coating with attractive new colour

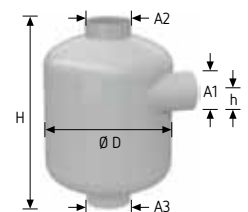

Type	Article No	Material Group	H mm	h mm	Ø D mm	A1 DN	A2 DN	A3 DN
T 170	8680000	73	328	55	206	50	65	65
T 270	8681000	73	400	65	280	65	80	80
T 380	8682000	73	528	75	490	80	100	100
T 480	8683000	73	710	115	480	125	150	150
T 550	8684000	73	896	125	634	150	200	200

Accessories

Reflex Exferro

- Solenoid insert for sludge separator
- 110°C/10 bar
- Magnetic bar screwed into thermowell/T-piece
- For uptake of ferromagnetic substances

Type	Article No	Material Group	Weight kg	Area Of Application	Installation Length (mm)
Exferro D 50 - 100 (60.3 - 114.3)	9258300	83	0.13	DN 50 - DN 100	300
Exferro D 125 - 200 (139.7 - 219.1)	9258310	83	0.63	DN 125 - DN 200	350
Exferro D 250 - 300 (273.0 - 323.9)	9258320	83	1.13	DN 250 - DN 300	400
Exferro D 350 - 600 (355.6 - 610)	9258330	83	1.63	> DN 300	500



Reflex Exiso

- Brass Exvoid, A 22-A 1 1/2 - 2"
- Brass Exdirt D 22-D 1 1/2 - 2"

Type	Article No	Material Group	Weight kg	Insulation thick-ness (mm)	Ø mm	H mm
A/D 22-1 1/2	9254811	82	0.15	15.0	125	225
A/D 2"	9254801	82	0.25	15.0	135	270

- Thermal insulation for Exvoid and Exdirt, steel version

Type	Article No	Material Group	Weight kg	Insulation thick-ness (mm)	Ø mm	H mm
DC 50-65 (60.3 - 76.1)	9254831	83	2.0	30.5	228	447
DN 80-100 (88.9 - 114.3)	9254841	83	3.0	30.5	290	567
DN 125-150 (139.7 - 168.3)	9254851	83	4.0	30.5	395	742



Pressure Loss Diagram for Exvoid, Exdirt, Extwin Standard Models

Connection	kvs, m³/h	V max. m³/h
Rp 3/4	10.7	1.25
Rp 1	17.2	2.00
Rp 1 1/4	31.8	3.70
Rp 1 1/2	40.0	5.00
Rp 2	56.1	7.50
DN 50	72.2	12.50
DN 65	121.7	20.00
DN 80	158.5	27.0
DN 100	244.3	47.0
DN 125	351.3	72.0

Connection	kvs, m³/h	V max. m³/h
DN 150	487.9	108.0
DN 200	780.6	180.0
DN 250	1185.7	288.0
DN 300	1696.4	405.0
DN 350	1790.3	500.0
DN 400	2242.7	650.0
DN 450	2687.9	850.0
DN 500	3196.0	1.060.0
DN 600	4416.7	1.530.0

Pressure loss calculation for all volume flows

$$\Delta p = \left(\frac{\dot{V}}{Kvs} \right)^2 \times 1 \text{ bar}, \dot{V} \leq V \text{ max}$$

Example:

Heating circuit 70/55°C, heat generator output 40 kW

Volume flow calculation

$$\dot{V} = \left(\frac{40 \text{ kW}}{4.2 \text{ kJ} / (\text{kg K}) \cdot (70-55) \text{ K}} \right) \times 3.600 \frac{\text{s}}{\text{h}} \times \frac{1 \text{ m}^3}{1.000 \text{ kg}} = 2.3 \text{ m}^3/\text{h} \rightarrow \text{selected size Rp 1 1/4}$$

$$\Delta p = \left(\frac{2.3 \text{ m}^3/\text{h}}{31.8 \text{ m}^3/\text{h}} \right)^2 \times 1 \text{ bar} = 5.23 \times 10^{-3} \text{ bar} = 0.53 \text{ kPa}$$

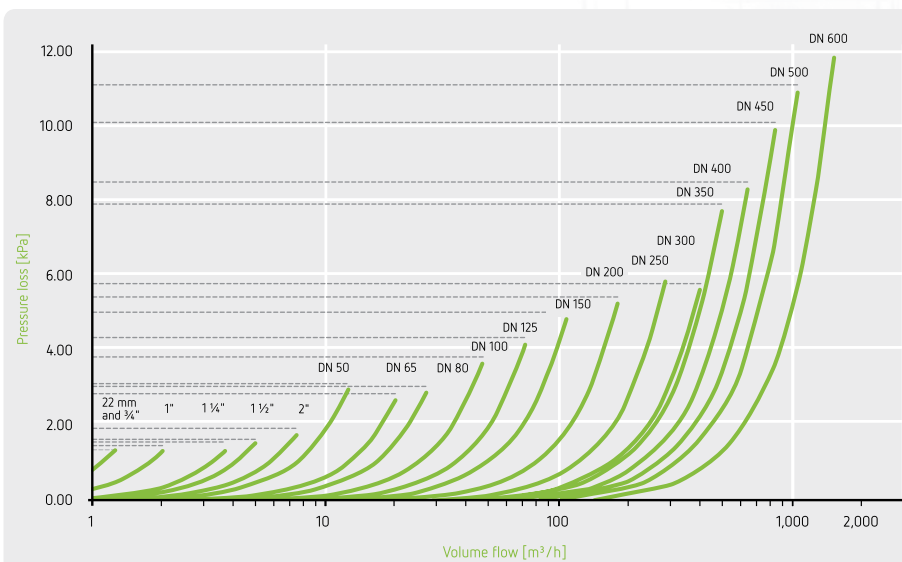

Reflex & Sinus Efficient Synergy



WHEN THE BEST COME TOGETHER IT, BECOMES HOT

The combination of both product lines in thousands of projects has proven the efficient synergy. Since the arrival of Sinus verteiler into the Winkelmann company family complementary products and system solutions from one stop service offer true benefit for the industry. We are looking forward discussing new possibilities for smart heating or cooling systems which will enlarge your horizon.

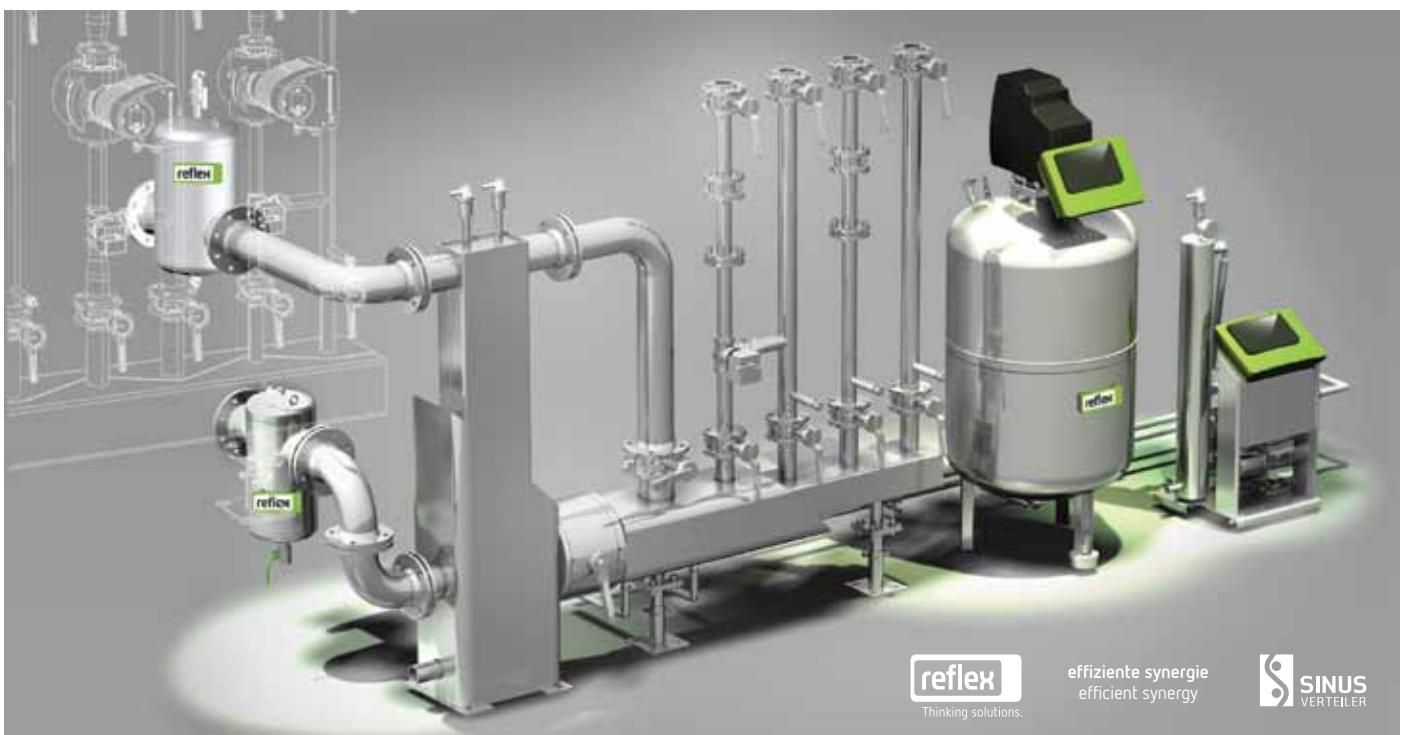

effiziente synergie
efficient synergy



Tailor Made Solutions

Solution: Servitec special systems

These systems operate in the same way as standard Servitec systems but their design underlines their extraordinary performance. Servitec special systems represent a genuine alternative to thermal degassing units and are also capable of degassing the make-up water directly. An installation like this essentially needs to be coordinated with professional experts on the operational side.

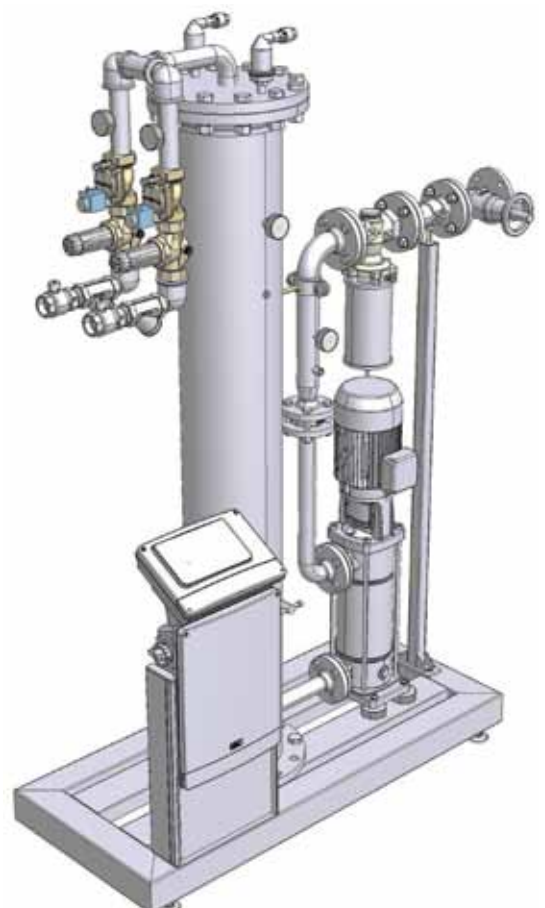



The Reflex brand name is well known in Europe and throughout the world as a major leader in pressure control technology for heating, chilled and potable water applications. Our world wide growth has allowed us to build several state-of-the-art manufacturing facilities supplying the industry with outstanding quality products. Reflex Winkelmann GmbH having its headquarters in the Westfalian city of Ahlen is not only a recognized leader in expansion vessels but also a significant manufacturer of advanced system solutions such as compressor and pump-controlled pressurisation systems, automatic air separation systems and hot water heaters.



Reflex has achieved its significant global growth today thanks to the unique combination of its world-class manufacturing skills, dedication to high-product quality at an affordable price and its commitment to continuous technical training of its people, our most precious resource. Our tradition goes back to 1898. This family oriented company started its core business in the elaboration of steel. A business in which we are recognised leaders today. The Heinrich Winkelmann Group form the parent company to a whole group of diversified manufacturing companies serving the heating segment and the whole automotive industry with over 4.200 employees. A tradition of more than a hundred years in this business makes us real experts today.



Thinking solutions.